

### General

The relay-based G2R26 coaxial microwave switching module provides a flexible configuration for many applications. It is the G2 version of our popular VRMR module series. It provides up to seven individual relay sections within a single module, using only three slots. Each relay element is individually shielded from each other and internal control circuitry.

Ultra-high reliability relay elements (>1,000,000 operations) are coupled with control and status circuitry. Sections can be field replaced without removing the module since each relay section is connectorized. The module also features hot-swap control technology for easy maintenance.

A unique power saving control circuit reduces DC power and cooling requirements for the module and increases overall reliability.

The number of sections included is determined by the model number. A reduced configuration can be further populated while in the field. Additional configurations are available on special order.

For control and DC power, the module must be installed into any G2 type mainframe controller. The mainframe must have either the -100, -D100, -600 or -D600 power supply configuration (-200 or -D200 by special order).

### Applications

- ATE systems
- Communication installations
- Antenna routing
- Switching high speed ECL/PECL data
- Satellite control centers
- Ground station IF signal routing

### Features

- High reliability relay elements
- DC to 26.5GHz bandpass (min)
- Flexible configuration expandable in field
- High performance stainless steel 3.5mm signal connectors
- Hot-Swap module technology
- Plug-in relay elements
- Rugged aluminum shielded enclosure
- Built-in control and status circuitry
- Individually shielded sections

### Configurations

- |                           |                  |         |
|---------------------------|------------------|---------|
| ■ G2R26-11X6-60 . . . . . | One 1x6 relay    | 3 slots |
| ■ G2R26-21X6-60 . . . . . | Two 1x6 relays   | 3 slots |
| ■ G2R26-31X6-60 . . . . . | Three 1x6 relays | 3 slots |
| ■ G2R26-41X6-60 . . . . . | Four 1x6 relays  | 3 slots |
| ■ G2R26-51X6-60 . . . . . | Five 1x6 relays  | 3 slots |
| ■ G2R26-61X6-60 . . . . . | Six 1x6 relays   | 3 slots |
| ■ G2R26-71X6-60 . . . . . | Seven 1x6 relays | 3 slots |

**NOTE-1:** By special order, the -20 suffix may be specified (-200 or -D200 power supply configuration).

**NOTE-2:** Other relay configurations besides 1x6 are available such as 1x5, 1x4, and 1x3 or a mixture of elements. Contact the factory.



Model G2R26-61X6-60

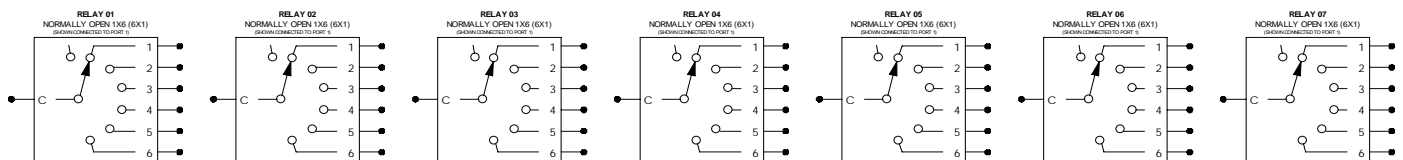

## Example Module Usage

Many different applications can be served by using the G2R26 relay module. The module provides a versatile building block for both 1xN type switching and XY matrix switching, or both.

Universal Switching Corporation builds systems utilizing this and other modules to meet customer applications. The diagram below illustrates a six input, six output blocking switching array. This allows the user to route 26GHz signals from any of the six inputs to any of the six outputs with 1 to 1 connections. Multiple output connections would cause proportional input loading since signal splitters are not included. Interconnection cabling is included at the factory using high performance 30GHz semi-flex cabling insuring the best possible performance.

Another example configuration (bottom of page 3) shows how the module relay sections can be cascaded in a "tree" configuration to achieve larger switching configurations. This example shows an expandable 60x1 (or 1x60) switching array. Semi-flex 30GHz cabling is utilized to connect the individual sections.

The upper diagram shows the physical layout of the 60x1 configuration when installed into a 3RU mainframe, the G2S600CE complete with C700-488 GPIB interface, plus a manual 64 key control panel.

Control firmware is factory configured so users only address a 60x1 or a 6x6 array, and not the complicated manipulation of the individual relay sections.

## Blocking 6x6 Switching Array

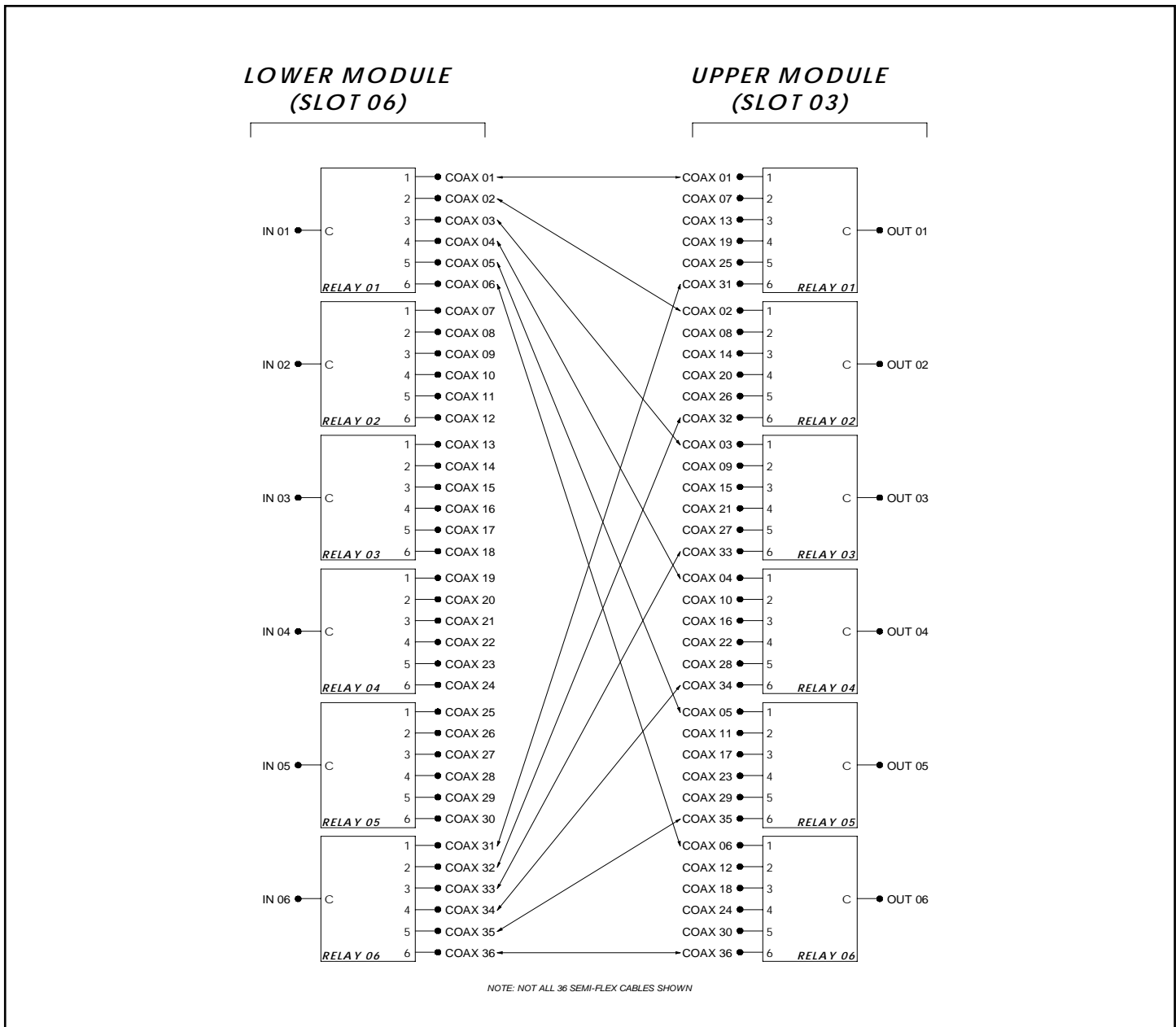

## Rear View of 60x1 System

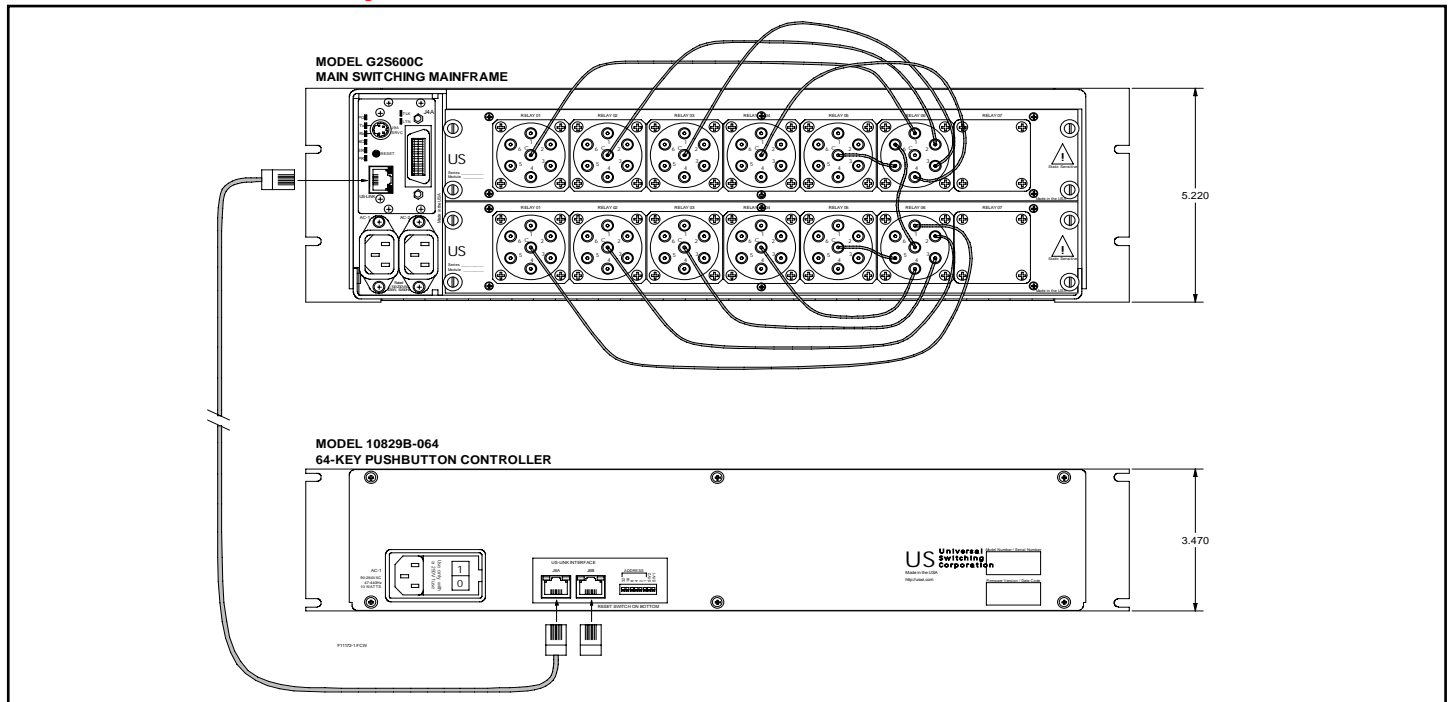

## Simplified 60x1 Schematic

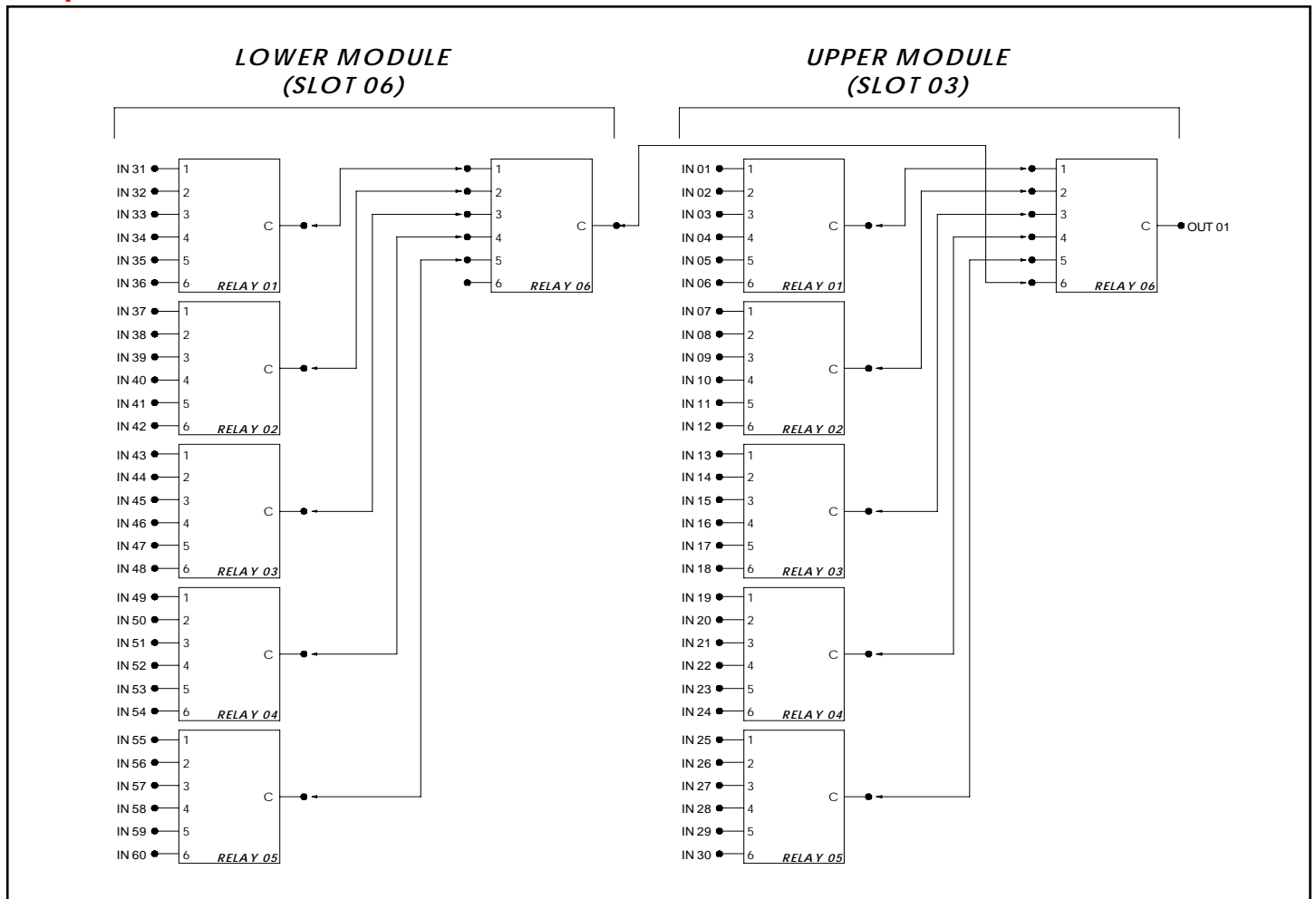

**Model G2R26-11X6-60**

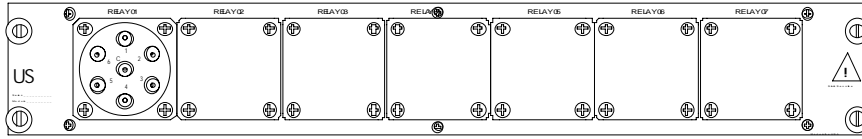

**Model G2R26-21X6-60**

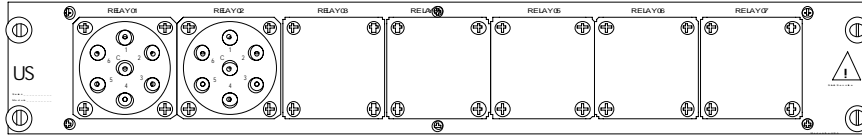

**Model G2R26-31X6-60**

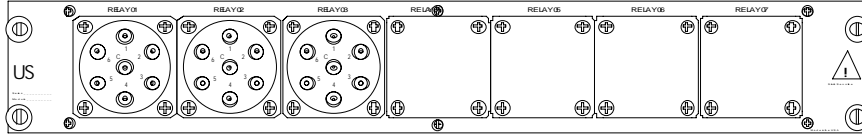

**Model G2R26-41X6-60**

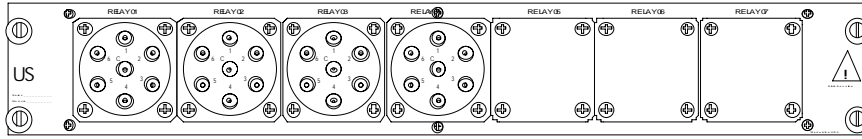

**Model G2R26-51X6-60**

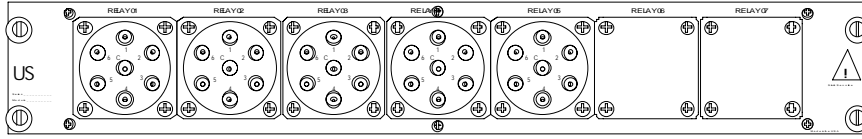

**Model G2R26-61X6-60**

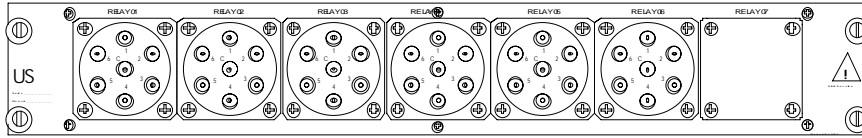

**Model G2R26-71X6-60**

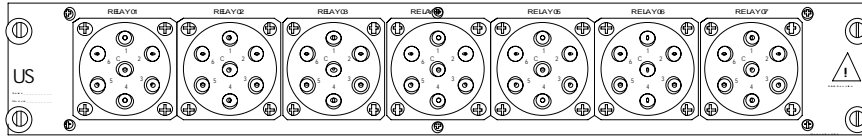

**Signal Specifications**

Switching elements . . . . .Relay-based  
 Operating mode . . . . .Normally open (no terminations)  
 Ports per relay section . . . .Six (1x6)  
 Number of sections . . . . .One to seven  
 Signal type . . . . .Analog, bi-directional  
 Signal connector . . . . .Stainless steel female APC 3.5mm  
 Frequency range . . . . .DC - 26.5GHz (min)  
 Impedance . . . . .50 ohm  
 Insertion loss . . . . .<0.30dB @ 8GHz  
 <0.40dB @ 12GHz  
 <0.50dB @ 18GHz  
 <0.80dB @ 26.5GHz  
 Repeatability . . . . .<0.10dB max  
 Crosstalk isolation (min) . . . .>70dB @ 8GHz  
 >65dB @ 12GHz  
 >60dB @ 18GHz  
 >50dB @ 26.5GHz  
 VSWR . . . . .<1.3 : 1 @ 8GHz  
 <1.4 : 1 @ 12GHz  
 <1.5 : 1 @ 18GHz  
 <1.8 : 1 @ 26.5GHz  
 Maximum power . . . . .30 watts @ 26.5GHz  
 Switching speed . . . . .<50mS (plus control time)

**General Specifications**

Module size . . . . .3 slot height  
 Control type . . . . .G2 compatible  
 Sparing . . . . .Hot-Swappable  
 Construction . . . . .Shielded aluminum case  
 Mating torque . . . . .8 inch pounds MAX  
 DC power . . . . .-100 or -600 configuration  
 +5V (digital), +15V (analog)  
 (or -200, -D200 by special order)  
 Weight . . . . .<5lbs (seven section)  
 Operating temp . . . . .0 to +70C  
 Non-operating temp . . . . -20 to +85C  
 Humidity . . . . .0 to 95% (NC @ +25C)  
 Contact life . . . . .>1,000,000 operations (per port)  
 MTBF . . . . .>85,000 hours  
 (per MIL-HDBK-217F, N1  
 ground benign @ +25C)

Universal Switching's policy is one of continuous development, and consequently the company reserves the right to vary from the descriptions and specifications shown in this publication.