

## General

The relay-based VXI-RR162 coaxial high frequency switching module provides a flexible high density configuration for many ATE or communication applications. It contains multiple relay sections for use in ATE stations, communication sites or other demanding applications requiring compact high performance switching.

It provides up to sixteen individual failsage 1x2 relay sections within a single C1 sized VXI module. The module is available in either 50 or 75 ohm impedances and can be ordered partially loaded for smaller applications. Ultra-high reliability relay elements (>5,000,000 operations) are coupled with control and status circuitry. Sections can be field replaced without special tools since each section is connectorized.

The number of sections included and the module impedance is determined by the model number suffix. A reduced configuration can be further populated while in the field. Additional configurations are available on special order.

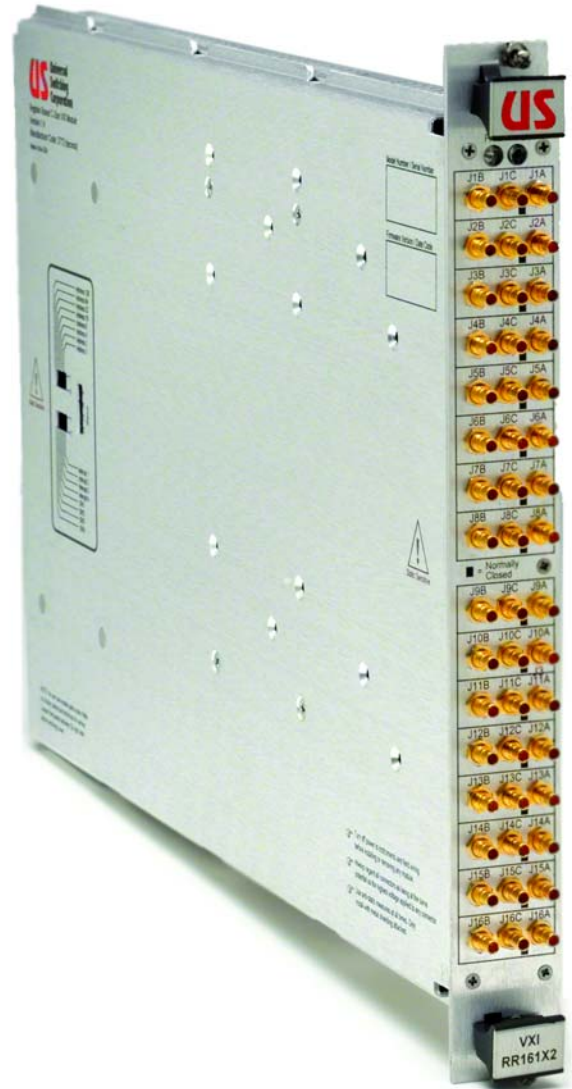

## Applications

- Communication installations
- Antenna routing
- ATE systems
- Switching high speed ECL/PECL data
- Satellite control centers
- Ground station IF signal routing

## Features

- Fast register-based control
- High reliability relay elements
- DC to 3GHz bandpass (min)
- High performance SMB signal connectors
- Field replaceable plug-in relay elements
- Rugged aluminum shielded C1 sized enclosure
- Built-in control and status circuitry
- Individually shielded sections
- LabVIEW drivers included

## Configurations

- VXI-RR162-516 . . . . .50 ohm, Sixteen 1x2 Sections
- VXI-RR162-512 . . . . .50 ohm, Twelve 1x2 Sections
- VXI-RR162-508 . . . . .50 ohm, Eight 1x2 Sections
- VXI-RR162-504 . . . . .50 ohm, Four 1x2 Sections
- VXI-RR162-716 . . . . .75 ohm, Sixteen 1x2 Sections
- VXI-RR162-712 . . . . .75 ohm, Twelve 1x2 Sections
- VXI-RR162-708 . . . . .75 ohm, Eight 1x2 Sections
- VXI-RR162-704 . . . . .75 ohm, Four 1x2 Sections

## Construction

The diagram below shows the overall physical configuration of the VXI-RR162 module. The top and bottom of the module contains venting slots for flow through cooling for proper operation in extreme temperature environments. The rugged aluminum enclosure provides a shielded environment internally for low noise signals. The module also provides aluminum slides for additional grounding for host VXI mainframes that provide conductive module slides.

Easily accessible during installation, the module has both the Logical Address and IRQ/function DIP-switches located on the side of the module (detailed below). Also located on the side is a set of status LED's to indicate various module functions during troubleshooting.

The module faceplate provides two additional status LED's. A red LED is labeled ERR to indicate error conditions, and a blue LED illuminates when the module is addressed by the VXI slot 0 controller.

Module control is register based providing fast easy control of the module's functions. LabVIEW drivers can be provided to simplify the control of the module.

## Example Module Usage

Many different applications can be served by the switch module. The module provides up to sixteen 1x2 relay sections for A/B selectors, source selection or other similar applications.

Universal Switching Corporation builds systems utilizing this and other modules to meet customer applications. Many other possibilities can be realized when coupled with other VXI switching modules too. Interconnection cabling can be provided by the factory using high performance semi-flex cabling insuring the best possible performance.

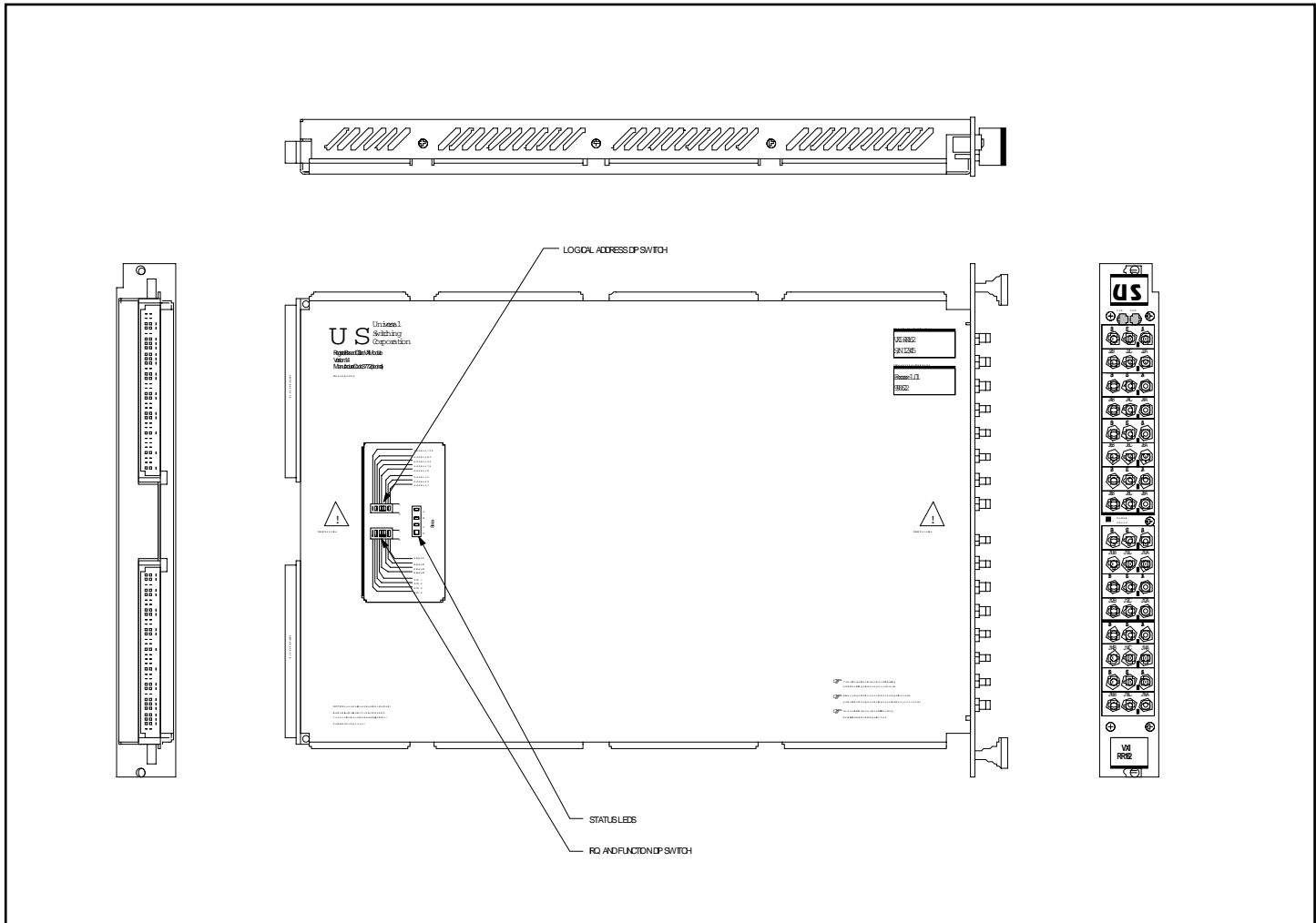

VXI-RR162-x04

VXI-RR162-x08

VXI-RR162-x12

VXI-RR162-x16

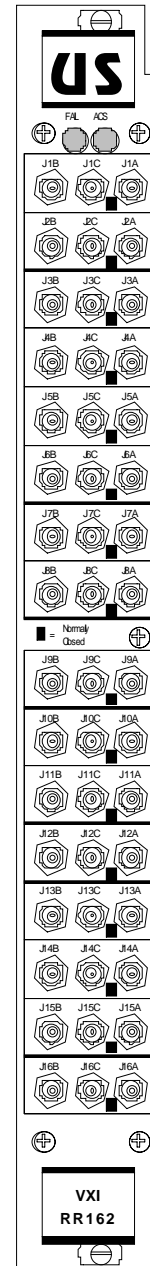
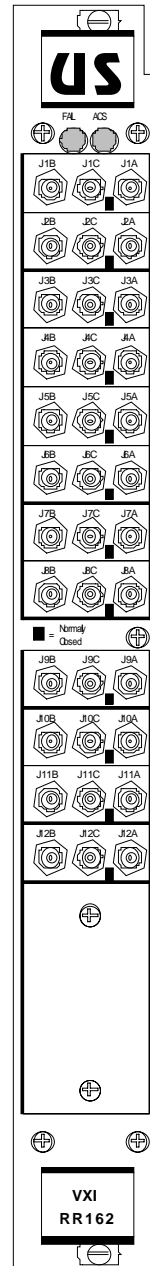
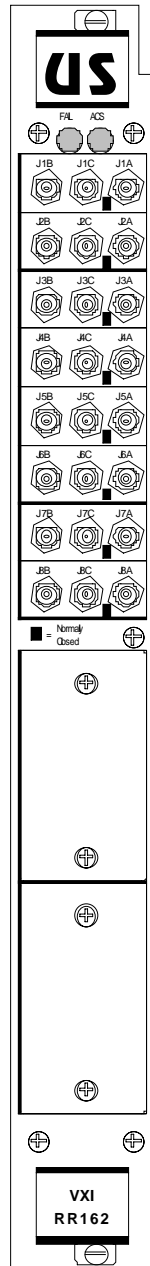
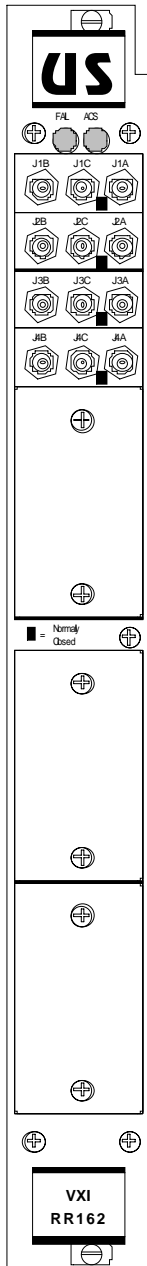

**NOTE:** Schematic is shown with relay sections in the default (fallback) position.

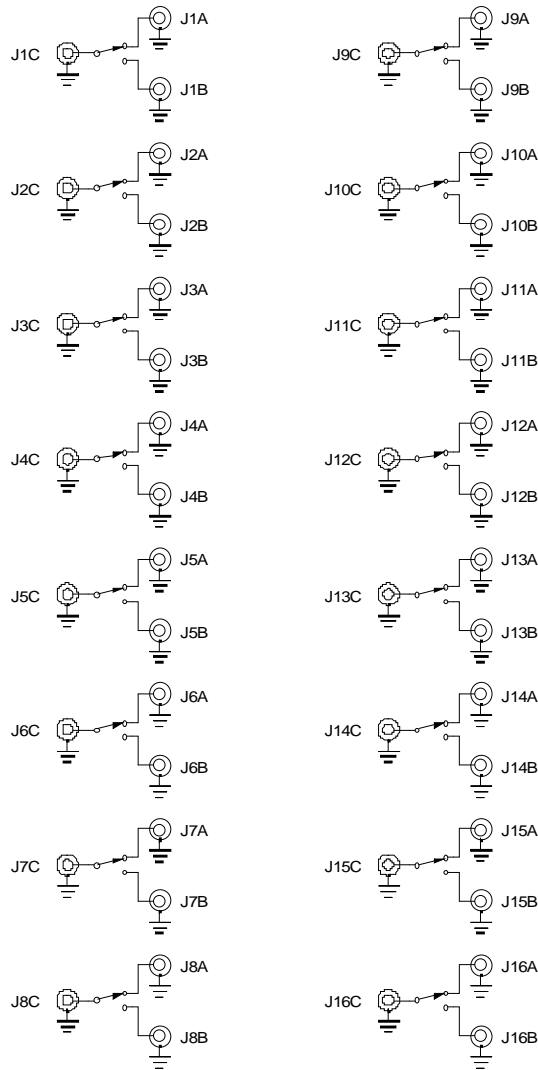

### Signal Specifications

Switching elements	Relay-based
Operating mode	Normally open (no terminations)
Ports per relay section	2 (1x2)
Number of sections	Four, eight, twelve or sixteen
Signal type	Analog, bi-directional
Signal connector	High performance female SMB
Frequency range	DC - 3GHz (min)
Impedance	50 or 75 ohm
Insertion loss	<0.30dB @ 500MHz <0.40dB @ 900MHz <0.50dB @ 1.5GHz <0.90dB @ 3GHz
Repeatability	<0.10dB max
Crosstalk isolation (min)	>65dB @ 500MHz >60dB @ 900MHz >55dB @ 1.5GHz >50dB @ 3GHz
VSWR	<1.4 : 1 @ 500MHz <1.5 : 1 @ 900MHz <1.7 : 1 @ 1.5GHz <2.0 : 1 @ 3GHz
Maximum power	.3 watts @ 40GHz
Switching speed	<50mS (plus control time)

### General Specifications

Module size	Single (C1)
Control type	Register based (V1.4)
Sparing	Field replaceable elements
Construction	Shielded aluminum case
DC power	+5V @ 1A plus 50mA/closure
Weight	<2lbs
Operating temp	0 to +70C
Non-operating temp	-20 to +85C
Humidity	0 to 95% (NC @ +25C)
Contact life	>2,000,000 operations (per port)
MTBF	>80,000 hours (per MIL-HDBK-217F, N1 ground benign @ +25C)

Universal Switching's policy is one of continuous development, and consequently the company reserves the right to vary from the descriptions and specifications shown in this publication.