



OPERATING AND PROGRAMMING MANUAL



10946B-SE10

Coaxial Four-Channel Backup System

State-of-the-Art Switching Solutions

Warranty

This **Universal Switching Corporation** product is warranted against manufacturing defects, and workmanship for a period of two years from the date of shipment from our factory. During this period, Universal Switching will, at its option, either repair or replace products which prove to be defective or out of specification per the original purchase order or contract. Damage by misuse or abnormal conditions of operation, or evidence of partial or complete disassembly beyond normal maintenance or expansion procedures voids this warranty. Since Universal Switching Corporation has no control over conditions of use for the products it manufactures, no warranty is made or implied as to the suitability for the customer's intended use, beyond such performance specifications as are made a part of the purchase order or contract.

Equipment shipped F.O.B. Universal Switching Corporation shall become the property of the Buyer upon delivery to the carrier. Equipment shipped F.O.B. Destination shall become the property of the Buyer upon delivery acceptance from the carrier. Damage during shipment, for items shipped F.O.B. Universal Switching Corporation should be handled by immediately requesting the carrier's inspection upon evidence of damage to the equipment. This warranty excludes all other warranties expressed or implied. Universal Switching Corporation shall not be liable for any special, indirect, or consequential damages.

For warranty service or repair, the Buyer shall prepay shipping charges to Universal Switching Corporation, and Universal Switching Corporation shall pay shipping charges to return the product to the Buyer. However, Buyer shall pay all shipping charges, duties, and taxes for products returned to Universal Switching Corporation from another country.

Universal Switching Corporation warrants that its software and firmware designated by Universal Switching Corporation for use with an instrument will execute its programming instructions when properly installed on that instrument. Universal Switching Corporation does not warrant that the operation of the instrument, or software, or firmware will be uninterrupted or error-free.

CONTENTS

1. INTRODUCTION TO THE 10946B-SE10	7
1.1. System 10946B-SE10 Configuration	8
1.2. System Expansion	8
2. SYSTEM SETUP	9
2.1. Preventing Electrostatic Discharges (ESD)	9
2.1.1. Anti-Static Protection	9
2.2. Safety Warnings and Markings	10
2.2.1. Declaration of Conformity (DoC).....	10
2.3. Serial Number Label	12
2.4. Unpacking	12
2.5. Environmental	13
2.5.1. Storage and Shipping	13
2.5.2. Operating Environment	13
2.5.3. Installation Site Parameters	13
2.5.4. Power Requirements (AC Version).....	14
2.5.5. Connecting AC Power	14
2.5.6. Powering ON (AC version)	15
2.5.7. Power Requirements (48VDC version).....	15
2.5.7.1. Connecting DC Power	15
2.6. Shipment of the System	16
2.6.1. Return Address.....	16
2.7. Connecting the Control Interface: 10946B-SE10	17
2.7.1. Configuring the Serial Port Hardware	18
2.7.2. RS-232C Serial Pin Assignment	20
2.7.3. RS-422A Serial Pin Assignment.....	20
2.7.4. RS-485 Serial Pin Assignment	21
2.7.5. Setting the Serial Port Baud Rate	21
2.7.6. Ethernet Port J7.....	22
2.7.7. Configuring the Ethernet Port J7	22
2.7.7.1. Setup.....	23
2.7.7.2. EG-SR-7150MJ Configuration Tool Screen.....	23
2.7.7.3. Telnet Control and Commands	24
2.7.8. Ethernet Port Pin Assignment	25
2.7.9. Ethernet Factory Default Settings.....	25
2.7.10. Self Test.....	26
2.7.11. Error Messages	26
2.7.11.1. Flash Programming.....	27

3.	SYSTEM CONFIGURATION.....	29
3.1.	Primary Input Port “A”	30
3.2.	Output Port “1”	30
3.3.	Backup Inputs “B”	30
3.4.	1:4 Backup.....	30
4.	FRONT PANEL OVERVIEW.....	31
4.1.	Display Features	31
4.2.	Control Pad Entries.....	32
4.2.1.	Normal or Backup Keys	32
4.2.2.	Mode Keys (1:1 and 1:4).....	33
4.3.	Front Panel Indicators	33
4.3.1.	LED Indicator Definitions	33
4.4.	Reset Switch.....	34
4.5.	Plug-in Power Supplies	34
5.	PROGRAMMING THE 10946B-SE10.....	35
5.1.	Special Notes for Using RS-485	35
5.1.1.	How to Address the Unit	35
5.1.2.	Changing the RS-485 Device Address.....	35
5.2.	Control Protocol	36
5.3.	Command Overview	36
5.3.1.	Command Details.....	37
5.3.1.1.	The Bi Command	37
5.3.1.2.	The Ni Command.....	38
5.3.1.3.	The Vi Command.....	38
5.3.1.4.	STORE Command.....	39
5.3.1.5.	RECALL Command	39
5.3.1.6.	Clear Command.....	40
5.3.1.7.	The 1:1, 2:2, or 1:4 Mode Command	40
5.3.1.8.	Download Switch Configuration Command	40
5.3.1.9.	RESET Command.....	41
5.3.1.10.	Firmware Version Request Command	41
5.3.1.11.	Front-panel Lock and Unlock Commands	41
5.3.1.12.	Enabling unsolicited ERROR attention message.....	42
5.3.1.13.	Disabling unsolicited ERROR attention message	42
5.3.1.14.	Request ERROR Messages	42
5.3.1.15.	Setting the serial port BAUD Rate	43
5.3.1.16.	Beeper Controls	44
5.3.1.17.	Enable AutoRecall (default)	44

5.3.1.18. Disable AutoRecall	44
5.4. National Instruments LabVIEW Drivers.....	45
6. ERROR CODES	47
7. REAR PANEL FEATURES	49
7.1. Construction	49
7.1.1. Mounting	49
7.2. Alarm Input Connector (J8)	50
7.3. TTL Driver Output Connector (J9)	51
7.3.1. Driver Port Capacity	53
8. SPARE PARTS LIST	55
8.1. Factory Recommended Spares List.....	55
9. SYSTEM 10946B-SE10 SPECIFICATIONS	57
10. RECORD OF CHANGES	59

TECHNICAL SUPPORT

Phone +1 818-381-5111

Fax +1 818-242-4868

Universal Switching Corporation
7671 North San Fernando Road
Burbank, CA. 91505-1073

Email support@uswi.com

1. Introduction to the 10946B-SE10

The 10946B-SE10 is a highly integrated coaxial switching system specially configured for routing signals in a four-channel backup arrangement with one serial interface and one Ethernet interface, in AC or DC powered configurations. Under remote program or front panel control, the user may connect a backup source in place of the four (4) standard signal inputs.

The 10946B-SE10 is designed for high performance analog signal switching and incorporates high reliability relays. The 6GHz bandpass makes the 10946B-SE10 a very versatile switch for connecting signals under remote or local control.

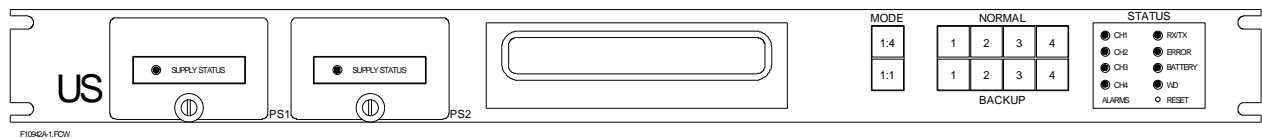

The 10946B-SE10 is designed for high reliability and high performance utilizing the latest in component technology. Front panel accessible and hot-swap redundant power supplies are included to provide for zero down time in the event of a power supply failure.

Some of the key features are:

- 6GHz bandpass
- Hot-Swap power supplies
- High reliability relays
- Embedded intelligent controller
- Front panel status LED's
- Vacuum fluorescent display (1x20)
- Illuminated control keys and display
- Powerful control command set
- Store and recall switching configurations
- Serial and Ethernet interfaces
- International AC power input (90-264VAC), DC versions available
- Compact and rugged enclosure design
- Flash field programmable

1.1. System 10946B-SE10 Configuration

The 10946B-SE10 is configured with one Ethernet control port and one RS-232C serial control port (the serial port can be easily configured for RS-422A or RS-485 by changing an internal switch setting and jumpers under the system cover). In addition, there is one serial alarm port and one serial driver port.

The unit can be ordered to operate from either AC (90-264VAC) or from DC voltages (48VDC).

1.2. System Expansion

As previously expressed in the warranty notice, Universal Switching Corporation voids the warranty of this system if it has been damaged by misuse or abnormal conditions of operation, or evidence exists of partial or complete disassembly beyond normal maintenance or expansion procedures.

The series G2 product line provides enhanced control, additional features, higher performance, and greater system flexibility than ever before; however, if you need to modify or expand your system please consult our application engineers for further assistance.



CAUTION: *The system is configured with particular power supplies that are not interchangeable with other models. Always replace power supplies with the same model number. Failure to observe this CAUTION could result in damage to equipment.*

2. System Setup

This section contains safety warnings and instruction on how to configure the switching system in preparation for operation.

It is very important to read and follow carefully the instructions provided below to assure safe and trouble-free operation and also to maximize the performance and expected lifetime of the system.

2.1. Preventing Electrostatic Discharges (ESD)

Many electronic components inside the system contain microcircuits and other sensitive devices that can be damaged internally by electrostatic discharges (ESD).

Electrostatic discharges (ESD) are the most severe form of electromagnetic interference. The human body can build up static charges that range up to many thousands of volts. This voltage can discharge very rapidly into an electrically grounded body or device. Damage to the internal components of a sensitive device can cause failure with just one static discharge.

The most common causes of ESD are the human body, low humidity, improper grounding, unshielded cables, and poor connections.

2.1.1. Anti-Static Protection

The components inside the switching system are extremely sensitive to electrostatic discharge (ESD). Electrostatic discharge can cause irreparable damage to the internal components of the switching system. The technician handling the component must know about static electricity and how to protect the components from ESD.



NOTE: Please follow normal ESD precautions and use anti-static protection to minimize or eliminate possible damage to the sensitive components included with the system.

2.2. Safety Warnings and Markings



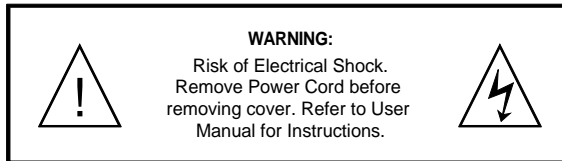





The system contains high voltage hazardous to human life and safety, and is capable of inflicting personal injury. The following warning marking is visible on the outside of the system. Note that this marking should never be removed and must remain on the system at all times.



2.2.1. Declaration of Conformity (DoC)

Declaration of Conformity (DoC) is included with the system when shipping to EU Member countries, only. The DoC also contains the serial number of the system.

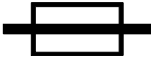
The following IEC symbols are utilized as appropriate throughout the unit. This table can be used as a reference.

	Meaning of Symbols	IEC Symbol Reference
	High Voltage: Risk of Electric Shock	ISO 3864, No. 3.3.1 and 5036
	Explanation Needed: Refer to this Operations Manual	ISO 3864, No. 3.3.1
	AC Voltage	5032
	Switch ON	5007
	Switch OFF	5008
	ON/OFF (alternate action with Push-ON, Push-OFF)	5010
	ON/OFF (alternate action with Push-ON, Push-OFF)	5016
	Protective Earth Ground	5019

2.3. Serial Number Label

The system includes a factory assigned serial number that is unique to each piece of equipment. There is also a label on the bottom of the unit indicating the version of the 10946B-SE10 and the MAC address.

2.4. Unpacking

The system is packed in antistatic material and shipped in multiple cartons of custom commercial packaging. Please pay attention when opening the shipping container not to inflict any cosmetic damage to the system. Check the packing list against the contents of the shipping container.



NOTE: Carefully inspect the packaging for shipping damage. Of damage is present, immediately notify Universal Switching Corporation and the carrier. Keep all shipping materials for the carrier's inspection.

If the contents are not complete, or there is any kind of mechanical damage or visible defects, you must notify the factory within five (5) days of receipt.

2.5. Environmental

The system may operate in a normal laboratory, a production, or a more rugged industrial environment without any additional considerations. However, protection against a dusty environment and temperature extremes which can cause condensation should be considered.

2.5.1. Storage and Shipping

The system may be stored or shipped in environments with the following limitations:

- Temperature: -20 degrees C to +85 degrees C
- Humidity: 0 to 90% (non-condensing)
- Altitude: 50,000 feet

2.5.2. Operating Environment

The system may be used in any environment with the following limitations:

- Temperature: 0 degrees C to +60 degrees C
- Humidity: 0 to 90% (non-condensing)

2.5.3. Installation Site Parameters

The installation site in which the system is to be installed should be as clean as possible. A dusty environment should be avoided. It is recommended that the system be installed in an environmentally controlled area equipped with an air filtration system.

The system has been designed to be mounted in a standard 19" equipment rack. The system is 1RU high (1.75"). All I/O and control signal connections to the system are at the rear, and therefore would come from inside the rack enclosure.

2.5.4. Power Requirements (AC Version)

The system (AC version) requires a power source of 90 to 264VAC single phase, 47 to 440Hz, and consumes <10 Watts of power. A 6-foot long power cord with standard NEMA 15A male plug is included with the system. For high reliability, front panel installed redundant hot-swap power supplies are utilized.

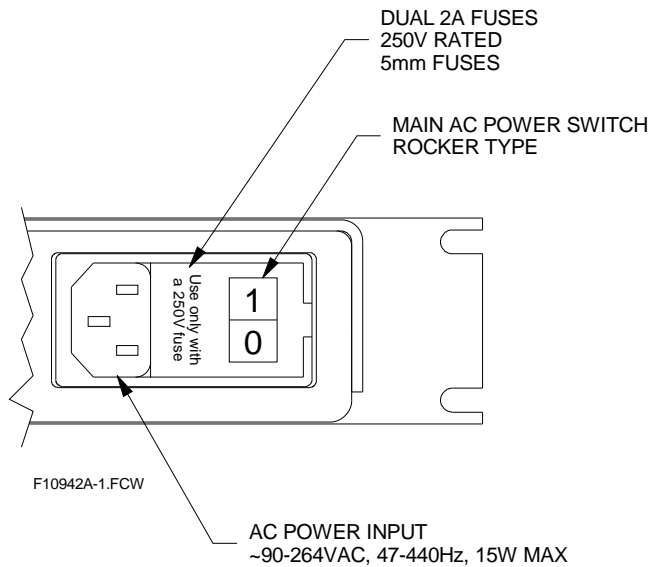

2.5.5. Connecting AC Power

The system is Safety Class 1 type equipment (equipment with an exposed metal chassis that is connected to earth via the power supply cord). Included with the 10946B-SE10 is a UL approved power cord.

The switching system has been designed and tested to meet strict safety requirements. A UL approved power cord is included with the system. The system integrator is responsible for the correct AC power cord specific for the destination country.

The power section on the rear of the system accepts the power cord providing the required grounding of the unit. A line filter is included in the power section to help eliminate spikes and transients from the AC power source.

2.5.6. Powering ON (AC version)

A rocker switch located on the power section on the rear of the system provides for powering ON or OFF the system.

2.5.7. Power Requirements (48VDC version)

The system (DC version) requires a power source of 48 Volts DC (32-72V range), and consumes <10W of power. For high reliability, front panel installed redundant hot-swap power supplies are utilized. Other input voltage ranges are available. The 48 volt version is identified by the appropriate voltage box adjacent to the input connector. Contact the factory for additional ranges.

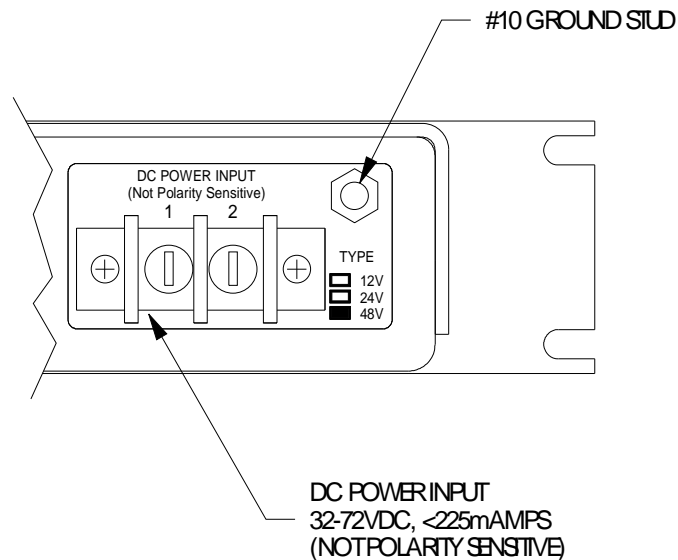

2.5.7.1. Connecting DC Power

DC power is supplied to the unit using the rear panel mounted screw terminals. The two terminals are marked "1" and "2", respectively, but any polarity may be used, since the DC powered system is equipped with an input rectifier. A ground terminal is also provided.

2.6. Shipment of the System

If any portion of the system is to be shipped back to the factory for service or modification, please attach a tag to the system. This tag must identify the current owner (including address and phone number) model and serial number of the unit, as well as a brief description or the required service or suspected problem.

Mark the container **FRAGILE** to help insure safe handling by the carrier. In correspondence, refer to the return item by the model number and serial number.



NOTE: Many problems may be solved over the phone. If return of the unit is necessary, contact the factory for an RMA number. No unit shall be accepted without an RMA number.

2.6.1. Return Address

When returning the unit for repair or service, please use the following address:

Universal Switching Corporation
7671 North San Fernando Road
Burbank, CA 91505 USA



NOTE: Additional information is available at the Universal Switching Corporation website: www.uswi.com.

2.7. Connecting the Control Interface: 10946B-SE10

The 10946B-SE10 features one configurable serial control port and one Ethernet control port. The serial interface connector is located on the rear of the unit and is a standard D-Type 9-position female. The Ethernet interface is located on the back panel and is an RJ-45 connector.

Model Number	Interface Type	Connector
10946B-SE10	Ethernet	RJ-45 Port (J7)
	Serial (RS-232, 422, 485)	DE-9S Port (J6)

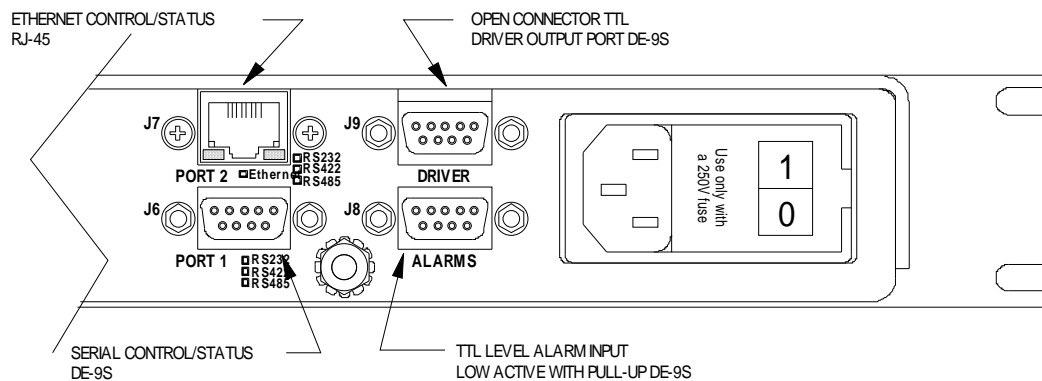

The serial interface port (J6) default configuration is **9600 baud, 8 data bits, 1 start bit, 2 stop bits, no parity, and no flow control**. In the case of the RS-485 multi-drop (addressable interface), the factory default address is 10. Changes to these settings are explained in the following sections.

2.7.1. Configuring the Serial Port Hardware

The serial ports are configurable for RS-232, RS-422 or RS-485. This is done by changing jumpers and the SW13-1 switch position located inside the unit as described below. The system cover must be removed.

NOTE: The default factory interface for a 10946B-SE10 system is RS-232.

FRONT OF UNIT

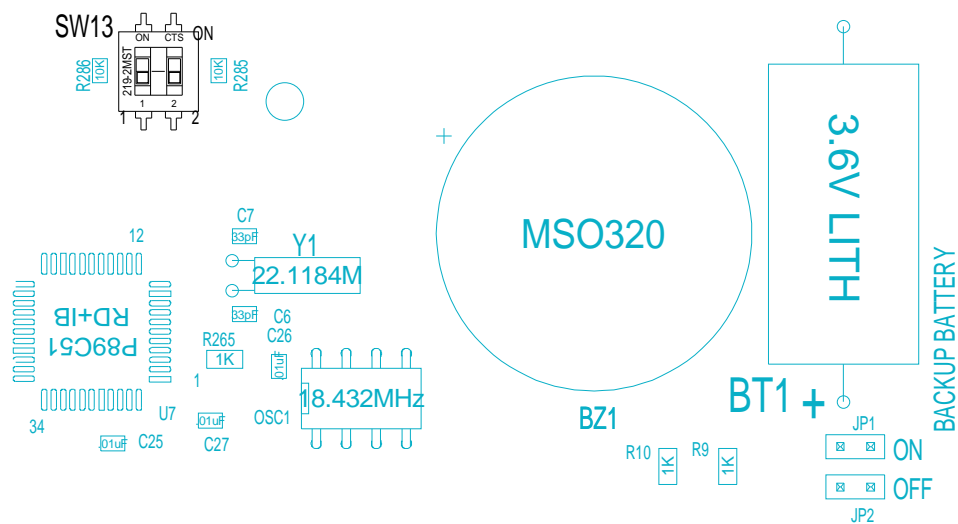

SW13, located near the front panel, determines whether or not an "address byte" is required to precede each command.

- SW13-1 and SW13-2 in the OFF position for RS-232 and RS-422
- SW13-1 and SW13-2 in the ON position for RS-485

NOTE: If the system is at the end of the RS-485 communication string, JP3 should be installed in the 1-2 position to provide termination.

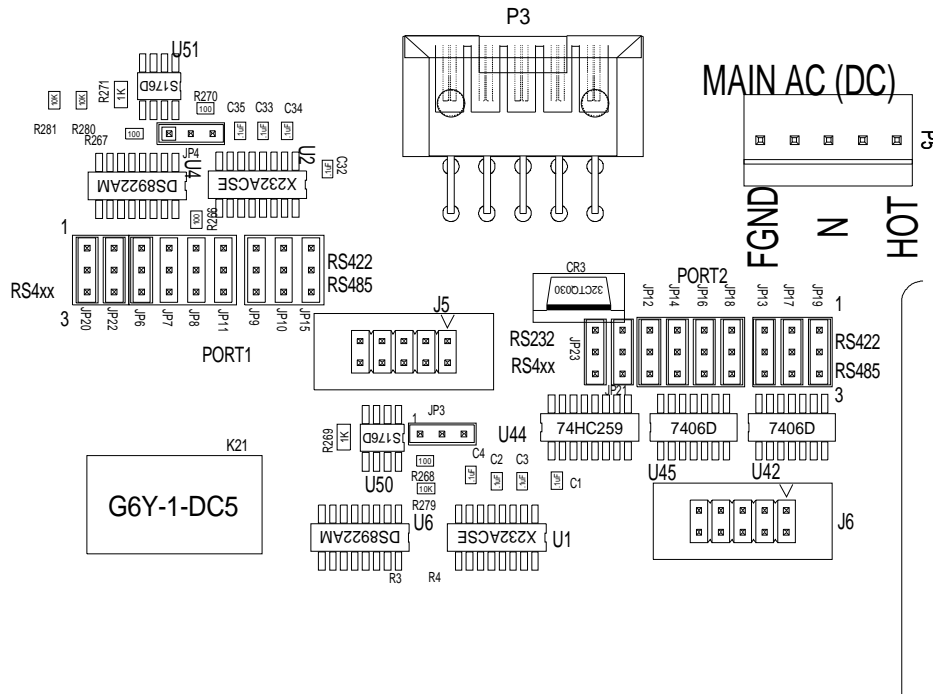

REAR PANEL J6 CONNECTOR									
	JP20	JP22	JP6	JP7	JP8	JP11	JP9	JP10	JP15
RS-232	1-2	1-2	1-2	1-2	1-2	1-2	X	X	X
RS-422	2-3	2-3	2-3	2-3	2-3	2-3	1-2	1-2	1-2
RS-485	2-3	2-3	2-3	2-3	2-3	2-3	2-3	2-3	2-3

- JP n in position 1-2 means towards front panel
- JP n in position 2-3 means towards rear panel
- JP n in position X means that the position of this jumper doesn't matter

2.7.2. RS-232C Serial Pin Assignment

The following table is the pin assignment for using RS-232C serial control. The serial port J6 connector is located on the rear panel.

Pin Number	Function	Designation
1	Not Used	
2	Transmit Data	TXD
3	Receive Data	RXD
4	Not Used	
5	Signal Ground	GND
6	Not Used	
7	Clear To Send	CTS
8	Ready To Send	RTS
9	Not Used	

2.7.3. RS-422A Serial Pin Assignment

The following table is the pin assignment when using RS-422A serial control. The serial port J6 connector is located on the rear panel.

Pin Number	Function	Designation
1	Transmit Data (-)	TXD -
2	Transmit Data (+)	TXD +
3	Receive Data (+)	RXD +
4	Receive Data (-)	RXD -
5	Signal Ground	GND
6	Clear To Send (-)	CTS -
7	Clear To Send (+)	CTS +
8	Ready To Send (+)	RTS +
9	Ready To Send (-)	RTS -

2.7.4. RS-485 Serial Pin Assignment

The following table is the pin assignment when using RS-485 serial control. The serial port J6 connector is located on the rear panel. An internal 100 ohm termination is enabled as shipped for RS-485. JP3 is set to the "2-3" position (OFF). If it is desired to have the port internally terminated, the jumper should be moved to the "1-2" position instead.

Pin Number	Function	Designation
1	TR Data (-)	485 -
2	TR Data (+)	485 +
3	Not Used	
4	Not Used	
5	Signal Ground	GND
6	Not Used	
7	Not Used	
8	Not Used	
9	Not Used	

2.7.5. Setting the Serial Port Baud Rate

When the 10946B-SE10 leaves the factory, **the serial port is configured for 9600 baud, 8 bits per character, 1 start bit, no parity, 2 stop bits, no handshaking.** Only the baud rate may be changed. All other parameters are fixed. The baud rate is changed by means of a remote control command; no DIP switches are available. There is one serial port included with the system. **The baud rate can be set to different settings.**



NOTE: All commands are standard ASCII and must be terminated by a CR (carriage return). Any LF (line feed) termination is ignored by the system.

To change the baud rate of the serial port, the following command is available:

I x x { C R }



NOTE: If configured for RS-485, a preceding "address byte" must be added at the beginning of the command.

The three character command is an "I" followed by the desired baud rate abbreviation as seen in the table below.

Ixx	Baud Rate
03	300
12	1200
24	2400
96	9600 (default)
19	19.2k
38	38.4k
56	56.7k
15	115.2k

After receipt of the "I" command (including a {CR}), the unit will return the same command using the original baud rate. The unit will then change to the new baud rate, and all successive commands will be interpreted using the new baud rate.

2.7.6. Ethernet Port J7

The 10946B-SE10 system features an Ethernet port (LAN interface). The Ethernet port (J7) uses a gateway module that converts TCP/IP (packet switched data) to serial data for communication with the 10946B-SE10 system. Conversely, the 10946B-SE10 converts serial data (at 230kbps) to packet switched data under TCP/IP for communication on LANs.

The Ethernet port is a 10/100Mbps auto sensing LAN interface. The user may utilize Telnet or any other software that supports Telnet (for example, Hyperterminal) for communication and control.

2.7.7. Configuring the Ethernet Port J7

The Ethernet interface is pre-configured and tested at the factory. However, if necessary, it is possible to reconfigure the Ethernet interface by using the EG-SR-7150MJ utility. Go to www.uswi.com and click on *Support*, and then click on the bullet point for *Software, Firmware, Drivers and Configuration Tools*. The EG-SR-7150MJ utility is downloadable from the website when you click on the icon.

2.7.7.1. Setup

The following steps guide the user through setup of the Ethernet port.

- Verify the system is connected to network or PC
- Logon to the Universal Switching Corporation website at www.uswi.com
- Download the EG-SJ-7150MJ file
- Extract the EG-SJ-7150MJ file
- Open the EG-SJ-7150MJ.exe file and follow the steps on the screen to install the utility and create a shortcut icon
- Double-click on the utility icon

2.7.7.2. EG-SR-7150MJ Configuration Tool Screen

A blank screen appears to allow configuring the system.

- Click on the Search button. The utility finds the gateway module.
- Select the correct MAC address from the Module list. (See the MAC address label on the system.) The configuration values of the selected module are displayed.
- Per user requirements, modify the IP Configuration Method area fields, and the Network Setting area fields. No other fields need to be modified.



NOTE: The baud rate may be changed but must match the system baud rate. (See 2.7.5.)

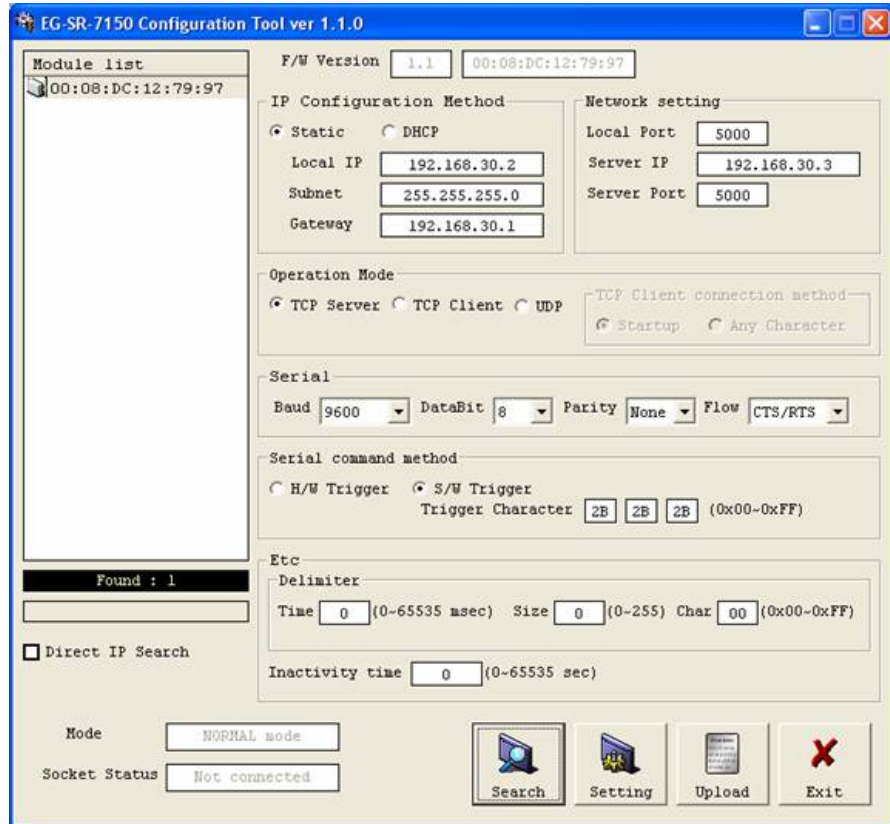

NOTE: In the TCP Server or Client mode, once the connection has been established, data is transparently transmitted in both directions (from Server to Client or from Client to Server).

- Click on the Setting button to save the configuration
- Click on the Exit button and exit the screen

2.7.7.3. Telnet Control and Commands

Telnet may be used for establishing communication with the system. Follow the steps below.

- Open a Telnet VT100 compatible terminal session
- Enter the following: Telnet <IP address> <port> (where IP address and port matches the values used in the configuration step)
- A connection is established
- Enter commands as described in Section 5
- Exit the Telnet session

2.7.8. Ethernet Port Pin Assignment

The following table is the pin assignment for the Ethernet control port (J7 connector) located on the rear panel.

Pin Number	Function	Designation
1	Transmit Data	TX+
2	Transmit Data	TX-
3	Receive Data	RX+
4	Not Used	
5	Not Used	
6	Receive Data	RX-
7	Not Used	
8	Not Used	

2.7.9. Ethernet Factory Default Settings

When the 10946B-SE10 leaves the factory, the Ethernet port is tested and hardware pre-configured per the following table.

IP Configuration Method	Static
Local IP address	192.168.30.2
Subnet mask	255.255.255.0
Gateway address	192.168.11.1
Local port number	5000
Server IP address	192.168.11.3
Server port number	5000

2.7.10. Self Test

The system's embedded controller performs a self-test immediately after power is applied. The self-test diagnostics are designed to run operational tests on the following system components:

- RAM
- ROM
- Vacuum Fluorescent Display (VFD)
- LED's on the front panel
- Beeper
- Power supply levels
- Internal CPU functions
- Current relay coil status

Upon powering ON the system, each of the above parameters will be verified consecutively. The self-test diagnostics may be started again from the remote interface.



NOTE: The self-test for the LED's, beeper, and front panel display are by observation. Failure cannot be detected by the main CPU.

2.7.11. Error Messages

Should a failure or error condition be detected, an error message is displayed on the front panel. For an explanation of the error codes, see Section 6.



NOTE: The System's main CPU continually monitors various functions while powered. Should errors be detected, the CPU illuminates the front panel "ERR" LED and make an audible tone on the beeper (if enabled).

2.7.11.1. Flash Programming

Firmware upgrades to the system are made available by downloading, via a standard PC's RS-232 (COM) port, to the main board (P10942B-01A) serial service port P14. Firmware upgrades can be done by the factory or in the field.

NOTE: The service port (P14) is accessible only after removing the cover from the unit.

The proper connector is a standard 9-pin computer ribbon cable, which connects between the P14 connector, and a PC computer's COM 1, 2, 3, or 4 port (or any serial control device's RS-232 port). Cables, as well as the program to flash the unit, are available from the factory. The procedure for flash programming a firmware upgrade in the field is as follows:

- Carefully remove the black cover assembly from the unit
- Connect the ribbon cable from unit interface port (P14) to the computer or serial control device's RS-232 port
- Set the JP5 jumper to the "ON" position
- Run flash program (WinISP)
- Set the JP5 jumper to the "OFF" position
- Disconnect the cable
- Replace the black cover on the unit

FRONT OF UNIT

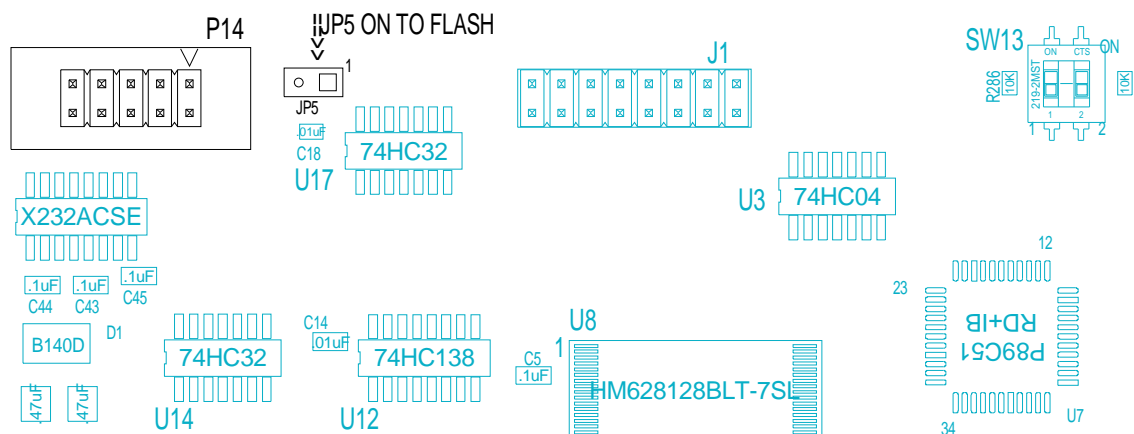

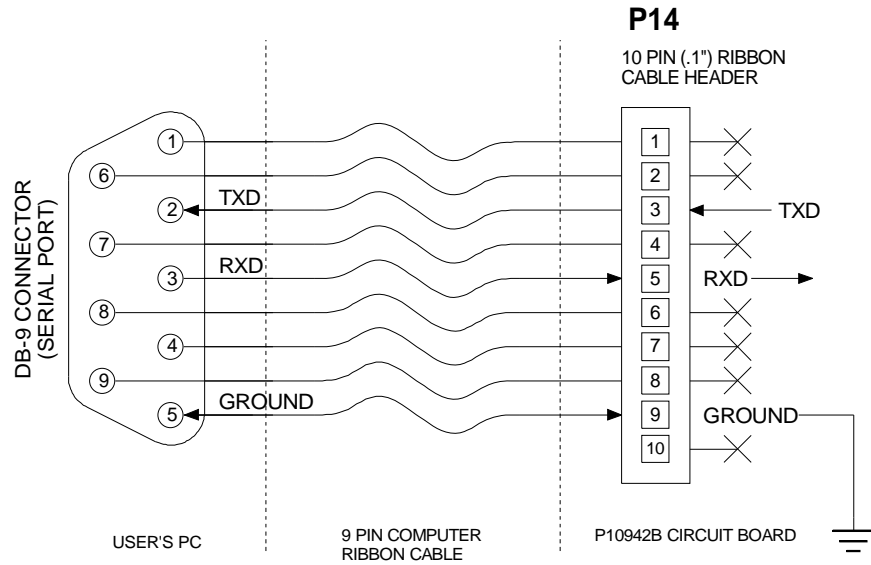

NOTE: Only the 3, 5, and 9 pins are connected to the circuit board. No harm will come to the unit if other pin connection paths are active from the controller's end.

3. System Configuration

This section describes the various features of the switching system and the basic construction.

The 10946B-SE10 is a 1RU high unit designed to receive up to four (4) coaxial signals on individual "relay sections". Under normal operation in the 1:1 mode, each relay section directly routes signals without degradation or modification to one (1) individual port.

All input and output signal connectors are SMA type. The primary inputs are designated on the rear panel as "A". The outputs are designated as "1". The "backup" inputs are designated as "B". The fail-safe relay sections are identified as Relay01, Relay02, Relay03, and Relay04. A relay section connector numbered "2" is terminated with 50 ohms external termination fixture at all times.

Default connections are A-1 and B-2. If the unit loses power, all primary "A" inputs connect to the associated output port "1". For example, Relay01 port "A" will be connected to port 1; Relay02 port "A" will be connected to port "1"; Relay03 port "A" will be connected to port "1"; Relay04 port "A" will be connected to port "1".

For each of the individual relay sections, a backup port exists and is designated as "B". Under remote or front panel control, the user may command the backup input "B" to be connected to the associated output port "1". For example, Relay01 port "B" may be connected to Relay01 port "1". When the associated backup port is connected, it is referred to as being in the 1:1 backup mode.

The unit includes a "ganged" 2:2 command mode named "H2". In this "ganged" mode, commands to Relay01 actuates both Relay01 and Relay03; commands to Relay02 actuates both Relay02 and Relay04.

A 1:4 Backup mode is available. The 1:4 mode actuates all four (4) relay sections and connects port "1" on each Relay Section to its backup port "B".

3.1. Primary Input Port “A”

The primary input ports are identified with “A” on the connector labeling. The primary ports are located to the upper left of each relay section (as viewed from the rear). This is the normal input for each of the four (4) relay sections of the unit and is “fail-safe” connected to the associated output port “1” should power be lost to the unit.

When in Backup mode, terminal “A” is terminated into 50 ohms at port “2” via an external termination fixture.

3.2. Output Port “1”

The output port “1” on each of the four (4) relay sections is always connected to either the primary input port “A” or the associated backup input port “B”. The output ports are identified as port “1” on each relay section on the rear panel, and located at the lower left corner of the relay.

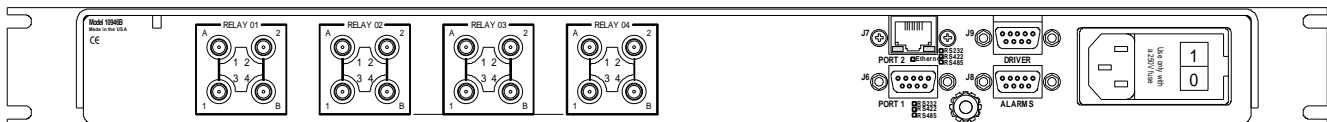

3.3. Backup Inputs “B”

Each relay section output port has an associated backup input port designated “B”. Should a backup port be selected while the unit is in the 1:1 mode, input port “B” is connected to output port “1”. When in the “normal” state or with power OFF, port “B” is disconnected and terminated into 50 ohms at port “2” via an external termination fixture.

3.4. 1:4 Backup

In the 1:4 mode, the backup command connects port “1” on all four (4) Relay Sections to their associated backup input port “B”. To exit the 1:4 mode and clear all connections, press the 1:1 mode button.

 **NOTE:** There is a 4-5 second delay to verify connections when enabling 1:4 mode. The BACKUP LEDs are illuminated when connection is complete.

4. Front Panel Overview

This section describes the features of the System 10946B-SE10 front panel control keypad and vacuum-fluorescent display, plus each of the individual status LED indicators. The explanation of each feature also provides a basis for their application and usage.

The control panel has been designed for ease of use and functionality. All control keys are back-illuminated with either a green or yellow LED.

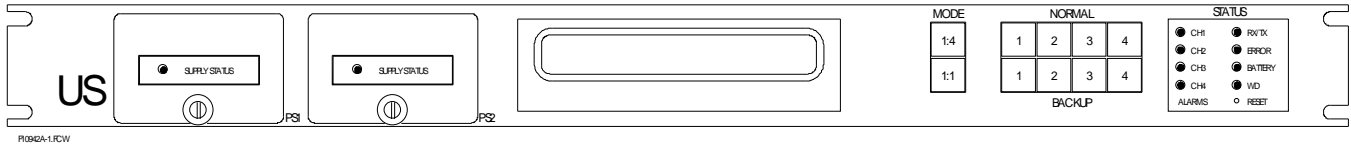

4.1. Display Features

The front panel display is a high contrast vacuum fluorescent display for rugged environments and long life. During normal operation, it displays various functions being processed and also displays error messages should an error occur.

4.2. Control Pad Entries

The front panel manual control keys are designed for switching operations in excess of 5 million entries per push-button. When a button is pressed, it provides both audible (if enabled) and tactile feedback to the operator.

4.2.1. Normal or Backup Keys

Two (2) rows of keys are available to select either a backup condition or normal condition for each of the four (4) switching sections. The upper row is the NORMAL mode selection (clear keys) and illuminates GREEN when selected. The lower row is utilized to select the BACKUP mode (YELLOW keys). When a backup is selected, the backup key illuminates YELLOW, and the associated "normal" key is turned off.

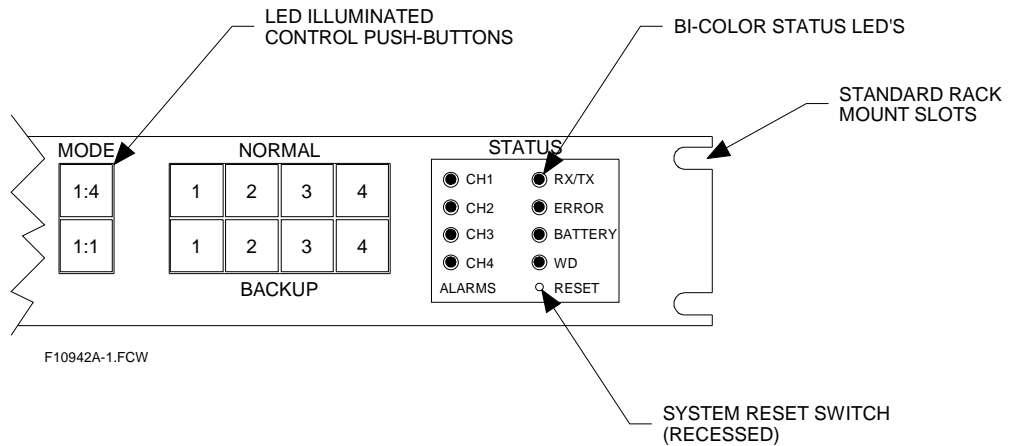

These keys provide local indication of the switch status as well as a means of local control. They reflect the status even when the switch is commanded from the serial control port or the external alarm inputs have created a selection.

4.2.2. Mode Keys (1:1 and 1:4)

A front panel means of backup mode selection is available. Two (2) keys labeled 1:1 or 1:4 select between the three (3) command modes. Only one mode can be selected at any one time (see Section 3). Pushing the "1:1" key toggles modes between the "1:1" (H1) mode, and the "2:2" (H2) mode. The "1:1" key is illuminated steady in H1 mode, while in H2 mode the key flashes.



NOTE: Pushing a mode key, or sending a mode changing command ("Hx") causes the switch to clear any current backup connections.

4.3. Front Panel Indicators

The front panel has eight (8) discrete bicolor LED's located on the right side of the front panel. They provide a direct visual status of main parameters.

4.3.1. LED Indicator Definitions

- **CH1 to CH4:** These LED's will always be GREEN unless an alarm condition is sensed. When an alarm signal level has been detected on the alarm input connector (J7) located on the rear panel, the associated indicator will illuminate RED as long as the alarm condition exists.
- **RX/TX:** This indicator is illuminated when the unit is receiving serial control data from the user on either of the serial port connectors (GREEN) or will be illuminated ORANGE when the unit is transmitting data to the user.
- **ERROR:** When a control command error, relay failure or some other similar error condition is sensed, the unit illuminates this LED with the color RED. Under normal conditions, the LED is off. An internal beeper will sound for 0.5 second in conjunction with an error condition (if enabled). The color RED will be present until the error condition is removed.
- **BATTERY:** The 10946B-SE10 system includes a lithium battery to support the internal memory features of the unit. Also included is a battery monitor. Normally this LED is illuminated GREEN, but should the battery voltage level be marginal, the LED will turn RED. Should the LED turn RED, the unit will require service at the factory.
- **WD:** This LED should always be GREEN. It is directly controlled by the embedded CPU. Should a catastrophic failure occur, causing the unit to freeze (stop running the internal firmware), the LED will turn a solid RED. The unit will then automatically reset.

4.4. Reset Switch

The 10946B-SE10 is equipped with a reset switch located in the lower right portion of the front panel. A small access hole is located directly below the status LED's. To reset the unit (reset does not change any downloaded parameters such as stored configurations), simply use a small object such as an opened paper clip to depress the switch located behind the access hole. It is about 0.3" behind the front panel. Pressing the Reset Switch has the same effect as cycling the power to the unit.

4.5. Plug-in Power Supplies

The 10946B-SE10 system is designed with redundant power supplies that are replaceable from the front of the unit while the power is ON. This is referred to as "hot-swappable" power sections. Two (2) identical supplies are included, each being secured to the chassis by one captive fastener. Loosening the captive fastener allows removing the power supply from the unit.

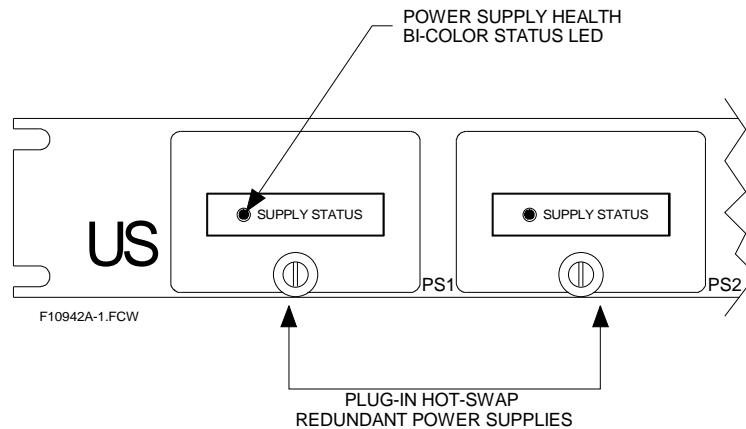

The power supplies are monitored by the embedded CPU and include a bicolor status indicator on the supply unit itself. With the indicators illuminated green, the power supplies are operating within tolerance. Should an indicator turn red, the supply has dropped below operational limits or has failed completely and requires service. Failure of a power supply is considered an error condition and is treated as such by the CPU.



NOTE: Plug-In Power supply types are specific to the type of power used for the system (AC or DC). These power supply module versions CANNOT be interchanged. Be careful when ordering spare power supplies to specify the correct power type.

5. Programming the 10946B-SE10

This section introduces basic programming information and provides examples to get you started with the system programming. **Before you start trying to communicate with the system, be sure to configure the serial port or Ethernet port of your controller to match the settings of the system.**

5.1. Special Notes for Using RS-485

Commands are comprised of standard ASCII characters, terminated with a **{CR}** (control code 13). **{LF}** is optional, and will be ignored by the system.

5.1.1. How to Address the Unit

When using the RS-485 interface to control the unit, all commands must be preceded with an address byte. The address byte must match the number displayed during powering the unit. **The factory default is "10".** For example, if the display for the address shows "A=10", the address byte must have the binary value 10. Also, all RS-485 responses will have the address byte inserted first in the string returned.

5.1.2. Changing the RS-485 Device Address

The address is settable only from the serial control port, or upon special request prior to shipment of the system from the factory. The device address range is from "01" to "99". To change the device address, the following command syntax must be sent:

A14{CR}

The above example changes the device address for the port to address "14". As usual, the command must be preceded by the current device address. The factory default is "10".



NOTE: Setting address to "00" will omit the requirement for the address byte from ALL command strings.

5.2. Control Protocol

The 10946B-SE10 has a unique streamlined control code to access the many features of the unit. Commands are composed of standard ASCII characters, terminated with a **{CR}** (control code 13). **{LF}** is optional, and will be ignored by the system.

5.3. Command Overview

The basic operations that can be programmed are as follows:

- **Bi**: Connect a backup port to an output port (backup)
- **Ni**: Disconnect a backup port from an output port (normal)
- **Vi**: Verify the status of a backup connection
- **Snn**: Store switching configuration
- **Rnn**: Recall switching configuration
- **CLR**: Clear all backup connections
- **H1, H2, or H4**: Set backup mode (1:1, 2:2 or 1:4)
- **DL**: Download switch configuration
- **RST**: Reset the system to default (clear all configuration data)
- **ER?**: Error status request
- **VER**: Request for firmware version
- **SON**: Enables unsolicited error attention message "**ER!**"
- **SOF**: Disables unsolicited error attention message "**ER!**"
- **Ixx**: Sets the baud rate of the serial communication port
- **LCK**: Locks the front panel controls
- **UNL**: Unlocks the front panel controls
- **BPx**: Controls conditions for internal beeper usage
- **RON**: Enables the system AutoRecall mode
- **ROF**: Disables the system AutoRestore mode
- **Ann**: Changes the factory default RS-232 address
- **Oann**: Outputs to the TTL driver port binary equivalent of "nnn"

5.3.1. Command Details

The serial and Ethernet control ports are located on the rear panel of the system. The serial port is a standard DE-9S female D-Type connector; the Ethernet port (J7) is a standard RJ-45 connector.

The command syntax is simple for the programmer to integrate into application software. Commands are sent using strings of standard ASCII characters. **All commands must be terminated with a carriage return {CR}**. A line feed {LF} is optional and will be ignored. As an option, National Instruments LabVIEW drivers are available from the factory upon request.

5.3.1.1. The Bi Command

- *Syntax: Bi*

The **Bi** command connects a backup input port to the specified section's output. The "i" is replaced by a digit representing the Section number to be backed up. For example, **B2{CR}** commands the unit to connect a backup input to the output port of Relay02. If the unit is in the 1:1 mode, the B input port is connected to 1. In 2:2 mode (H2), only B1 and B2 are valid commands as they also switch backup channels 3 and 4 respectively.

Note that when a backup input is connected, the primary input port is disconnected and terminated into 50 ohms.



NOTE: It is not considered an error condition to command the unit to connect the backup port if the backup port is already connected.

When the command has been received, executed and verified by the embedded CPU, the unit echoes the same command back to the user via the serial control port followed by a **{CR}**. If an error occurs, the appropriate error code is returned instead of the command. The front panel LED illuminated keys reflects any changes to the configuration.

5.3.1.2. The Ni Command

- *Syntax: Ni*

The **Ni** command disconnects a backup input port from an output port and returns the specified section to the “normal” connection where the primary input (A) is connected to the associated output port (1). The “i” is replaced with a digit representing the desired section number. For example, the command **N4{CR}** disconnects any backup input currently connected to the output of Relay04.



NOTE: It is not considered a error condition to command the unit to disconnect the backup port if the backup port is not currently connected.

When the command has been received, executed and verified by the embedded CPU, the unit echoes the same command back to the user via the serial control port followed by a **{CR}**. If an error occurs, the appropriate error code is returned instead of the command. The front panel LED illuminated keys reflect any changes to the configuration.

5.3.1.3. The Vi Command

- *Syntax: Vi*

The **Vi** command verifies the status of an output port to see if it is in the normal or backup mode. The “i” is replaced with a digit representing the desired section number to be verified. For example, sending the command “V3{CR} will verify the status of Relay03.

The unit returns **B3{CR}** if the port is in the backup mode or **N3{CR}** if the section is in the normal state. If an error occurs, the appropriate error code is returned instead of the verification status.

When the command has been received, executed and verified by the embedded CPU, the unit echoes the same command back to the user via the serial control port followed by a **{CR}**. If an error occurs, the appropriate error code is returned instead of the command.

5.3.1.4. STORE Command

- *Syntax: Snn*

A command is available to store switching configurations in a memory location for retrieval. This simplifies control depending upon the unit's application. The command includes a two-digit memory location number between 01 and 99 to store the switching configuration. The command begins with the character "S" and is followed by the two (2) digit memory location number. For example, the command **S15{CR}** stores the current switching configuration to memory location #15.

When the command has been received, executed and verified by the embedded CPU, the unit echoes the same command back to the user via the serial control port followed by a **{CR}**. If an error occurs, the appropriate error code is returned instead of the command. Sending the command to a previously assigned memory location overwrites the location with the new configuration.



NOTE: Only the switching configuration is stored with this command. All other parameters are automatically stored.

5.3.1.5. RECALL Command

- *Syntax: Rnn*

Used in conjunction with the STORE command, the RECALL command is used to clear any current configuration and recall a stored configuration from the battery backed RAM. The command recalls the configuration from a memory location assigned a two-digit number between 01 and 99. The command begins with the character "R" and is followed by the two-digits. For example, the command **R06{CR}** recalls the switching configuration stored in memory location 06.

When the command has been received, executed and verified by the embedded CPU, the unit echoes the command back to the user via the serial control port followed by a **{CR}**. If an error occurs, the appropriate error code is returned instead of the command.



NOTE: It is not considered an error condition to command the unit to recall the same memory configuration more than once.

5.3.1.6. Clear Command

- *Syntax: CLR*

The CLEAR command is utilized to restore all “normal” paths at the same time. If any backup connections are made, they are disconnected and the primary inputs are reestablished. The command **CLR{CR}** is echoed back to the user’s controller when it is properly executed. If an error occurs, the appropriate error message is returned instead.

5.3.1.7. The 1:1, 2:2, or 1:4 Mode Command

- *Syntax: Hn*

The 10946B-SE10 has the ability to be in one of three (3) modes. They are referred to as 1:1, 2:2, or 1:4 mode. In the 1:1 mode, there is an individual backup port associated to each output port. However, when the unit is in the 1:4 mode, all backup inputs are available for all 4 outputs. The 2:2 mode works like the 1:1 mode, except that channels 1 and 3 and channels 2 and 4 are switched together.

The string **H1{CR}** sets the unit in 1:1 mode, while **H2{CR}** enables the 2:2 mode. To select the 1:4 backup mode **H4{CR}** must be sent. To exit 1:4 mode, send **H1{CR}** or **CLR{CR}**.



NOTE: There is a 4-5 second delay to verify connections when enabling 1:4 mode. The BACKUP LEDs are illuminated when connection is complete.

When the command has been received, executed and verified by the embedded CPU, the unit echoes the same command back to the user via the serial control port followed by a **{CR}**. If an error occurs, the appropriate error code is returned instead of the command. The front panel LED illuminated keys reflect the current control mode.

5.3.1.8. Download Switch Configuration Command

- *Syntax: DL*

The user may interrogate the system as to the current status of the switching configuration. The command **DL{CR}** returns a status string. The unit returns a string six (6) characters long plus the **{CR}**. The first two (2) characters indicate the current control mode and are either “H1”, “H2”, or “H4”.

The next character represents the status of section #1 and is either an “N” indicating normal mode or a “B” indicating a backup condition. The balance of the string represents sections 2 through 4 respectively. An example of a string indicating that the unit is in the 1:1 mode and that both sections 2 and 4 are in the backup condition is as follows:
H1NBNB{CR}

5.3.1.9. RESET Command

- *Syntax: RST*

Sending the command **RST{CR}** initiates the unit into a self test similar to the power-up test (i.e.: a warm reboot). The unit returns the same command **RST{CR}** and resets after five (5) seconds. If the AUTO-RECALL setting is ON (factory default), the unit restores the last switching configuration prior to receipt of the reset command.

If the AUTO-RECALL setting is OFF, the unit is returned to the “normal” mode where all primary input ports are connected to the associated output port, and all backup ports are terminated into 50 ohms.

5.3.1.10. Firmware Version Request Command

- *Syntax: VER*

The user may request the firmware version of the unit by sending the command **VER{CR}**. The unit responds with the full model number followed by the firmware version number.

5.3.1.11. Front-panel Lock and Unlock Commands

- *Syntax: LCK or UNL*

Critical installations may require the user to lock the front panel control from unauthorized or inadvertent configuration changes at the front panel controls. The command **LCK{CR}** locks the front panel control keys. The front panel display represents the current status of the switching configuration but the user is not able to control the unit from the front panel. Turning the unit off does not relinquish the front panel locking since this is stored in memory. To unlock the front panel controls, the command **UNL{CR}** must be sent.

When either command has been received, executed and verified by the embedded CPU, the unit echoes the same command back to the user via the serial control port followed by a **{CR}**. If an error occurs, the appropriate error code is returned instead of the command.

5.3.1.12. Enabling unsolicited ERROR attention message

- *Syntax: SON*

A command is available to enable the unsolicited error alert if it has been disabled. The command **SON{CR}** enables the unsolicited error attention message “**ER!**”.

When errors occur, the unit can send an unsolicited error alert message (**ER!**). Messages that are automatically sent to the user without request are considered “unsolicited” messages. Some users may not be able to handle this unexpected data communication since special serial port handling is required to capture the error alert message.

If an error occurs, the unit does not send the error message, but sends an alert message indicating that an error has occurred and should be serviced by the user’s controller. The actual error(-s) can be retrieved using the **ER?{CR}** command.

5.3.1.13. Disabling unsolicited ERROR attention message

- *Syntax: SOF*

Some users may not be able to handle this unexpected data communication since special serial port handling is required to capture an unsolicited error alert message. The command **SOF{CR}** disables the unsolicited error attention message “**ER!**”.

5.3.1.14. Request ERROR Messages

- *Syntax: ER?*

To request error information from the internal error stack, the string **ER?{CR}** returns messages. The messages are formatted as **Ennn** where the “nnn” represents a three-digit code. If the message **E000{CR}** is received, no errors have occurred and the error stack is empty. *If there are error messages, the user should keep sending the “ER?” command until the “E000” is received.*

5.3.1.15. Setting the serial port BAUD Rate

- *Syntax: Ixx*

The 10946B-SE10 has selectable baud rates. **The serial port is configured for 9600 baud, 8 bits per character, no parity, 2 stop bits, no handshaking.** Only the baud rate may be changed. All other parameters are fixed. The baud rate is changed under program control, not by DIP switch settings.

To change the baud rate of the serial port, the following command is available:

I x x { C R }

The three (3) character command is an "I" followed by the desired baud rate abbreviation as seen in the table below.

Ixx	Baud Rate
03	300
12	1200
24	2400
96	9600 (default)
19	19.2k
38	38.4k
56	56.7k
15	115.2k

After receipt of the "I" command (including a {CR}), the unit returns the same command using the original baud rate. The unit then changes to the new baud rate, and all successive commands are interpreted using the new baud rate.

5.3.1.16. Beeper Controls

- *Syntax: BPx*

The internal beeper may be set to operate under different conditions. The command is **BPx{CR}** where the “x” is replaced by a digit from the table below.

BPx	Function
0	Beeper Off
1	Error Condition Beep Only
2	Keypad Entry Beep Only
3	Error Condition and Keypad Entry

The command is echoed back to the user’s controller when it is properly executed including a **{CR}**. If an error occurs, the appropriate error message is returned instead.

5.3.1.17. Enable AutoRecall (default)

- *Syntax: RON*

To enable the unit to recall the last switching state it was in prior to being powered down, the command **RON{CR}** must be sent. This enables the AutoRecall mode (factory default setting).

The command is echoed back to the user’s controller when it is properly executed including a **{CR}**. If an error occurs, the appropriate error message is returned instead

5.3.1.18. Disable AutoRecall

- *Syntax: ROF*

To have the unit power to a known state (all normal condition) the AutoRecall mode must be disabled. To disable the AutoRecall mode, the command **ROF{CR}** must be sent. This disables the AutoRecall mode (factory default setting is RON).

The command is echoed back to the user’s controller when it is properly executed including a **{CR}**. If an error occurs, the appropriate error message is returned instead.

5.4. National Instruments LabVIEW Drivers

Universal Switching Corporation can provide National Instruments LabVIEW drivers upon request. The latest version is available at our WebSITE (<http://uswi.com>).

The drivers are referred to as Virtual Instruments, or more commonly as VI's. A view of the standard VI screen is shown below.

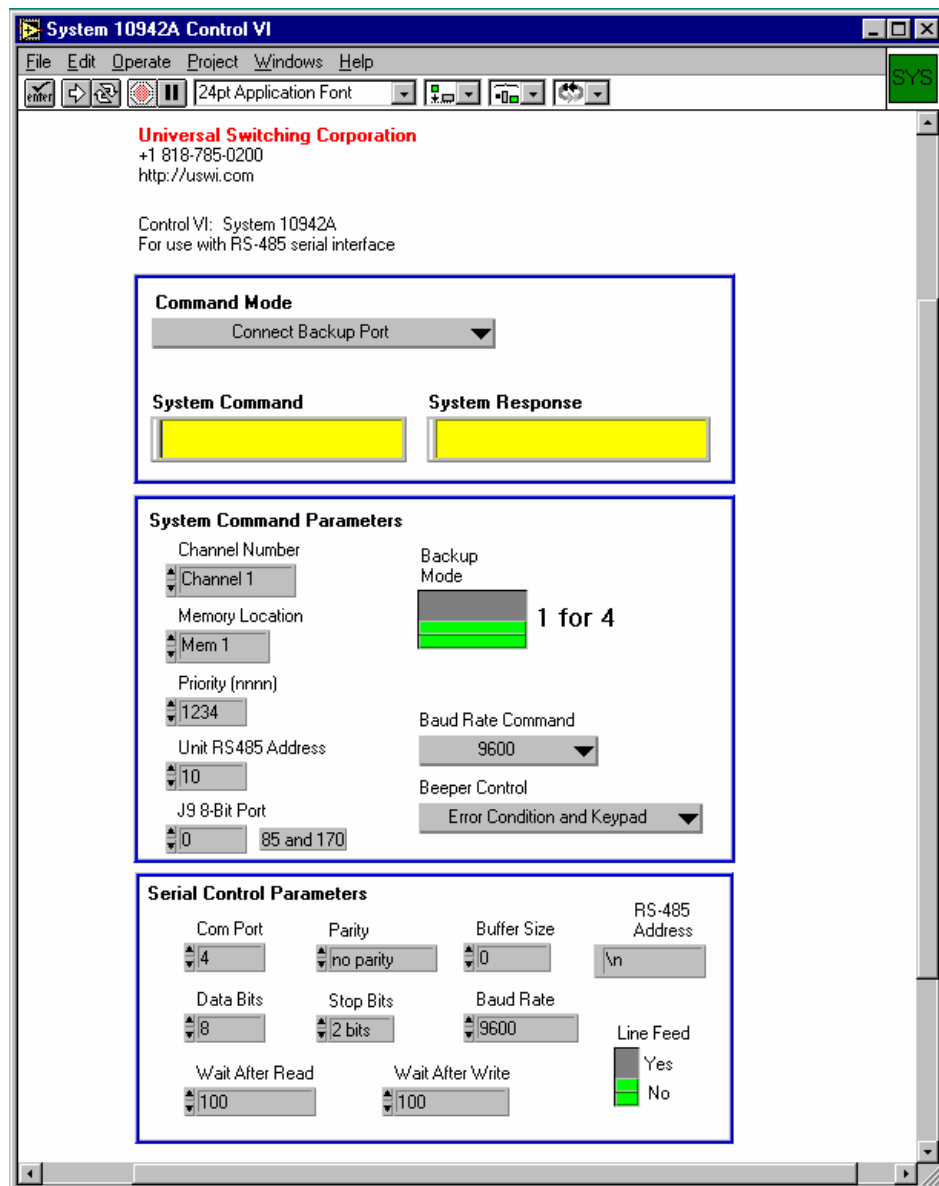

6. Error codes

If an error occurred during execution of a command, one of the error codes listed below is returned:

- E002 Specified module port does not exist
- E003 Unrecognized command
- E004 Specified module is already in backup mode
- E005 Specified port is already in backup condition
- E007 Specified port is not connected to backup port
- E008 Specified memory location is empty
- E009 Invalid command argument received
- E012 Random access memory checksum error
- E013 Read only memory (EPROM) checksum error
- E015 General power failure
- E023 Bad key bad entry
- E027 Bad coil voltage sensed during verification
- E040 Power Supply #1 (left) is LOW
- E041 Power Supply #2 (right) is LOW
- E042 Power Supply #1 (left) is not installed
- E043 Power Supply #2 (right) is not installed

7. Rear Panel Features

The system's signal connectors are located directly on the rear panel. The signal connectors are SMA female. An industry standard SMA male plug mates with these connectors. They are sufficiently spaced to connect and disconnect cables without the use of special cabling tools.

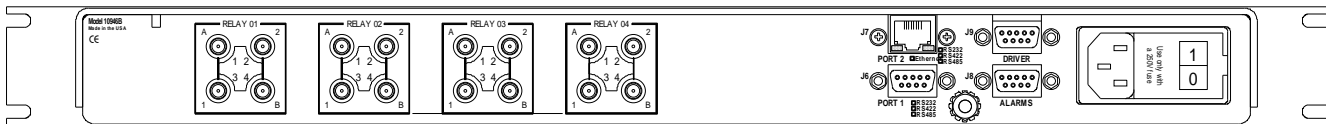

CAUTION: Recommended SMA connector torque is 8 lb-in. Do not exceed Maximum 12 lb-in. Failure to observe this CAUTION could result in damage to equipment.

7.1. Construction

The mainframe is constructed from a rugged aluminum frame. The frame is gold irradiate plated for resistance to corrosion elements and to provide excellent ground conductivity. The exterior of the mainframe cover is painted black with texture coated epoxy paint per MIL-STD-595B. Fingerprints and other markings do not easily appear on the finish because of the texture coating, plus it provides an additional measure of protection against possible corrosion.

7.1.1. Mounting

The front panel is 1/8" (.125") thick, which is standard for most 19" rackmount equipment, and also contains standard RETMA slots for rackmount equipment. The unit is 1RU (rack unit) high (1.72").

7.2. Alarm Input Connector (J8)

The 10946B-SE10 provides a means of directly accessing control of the switching configuration. An ALARM input connector is available on the rear panel (J8). The connector is a D-Type female DE-9S connector that can be mated to any industry standard DE-9P male plug. The implementation for the alarm inputs is up to the user, but it provides four (4) TTL compatible lines to directly select a section to be “backed-up” depending upon the control mode (1:1 or 1:4).

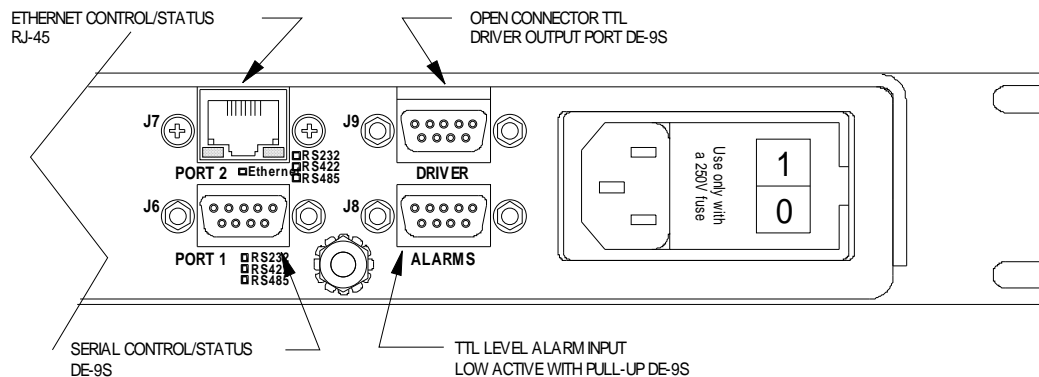

There is a control line for each section. The control lines are pulled high (10K ohm) so external pull-up resistors are not required. The lines are active low meaning that a TTL low (<0.8V) will select the associated section. The 10946B-SE10 firmware keeps the section in the backup mode until instructed to change from the serial or Ethernet control port or front panel controls even if the alarm is cleared.

Pin	Function
1	Alarm 1
2	Alarm 2
3	Alarm 3
4	Alarm 4
5	GND
6	GND
7	GND
8	GND
9	GND

7.3. TTL Driver Output Connector (J9)

A rear panel connector J9 provides the user with a TTL compatible driver output for various external tasks. It is an 8-bit port that the user can “write” to for controlling external relays or digital equipment. The connector is a D-Type female DE-9S connector that can be mated to any industry standard DE-9P male plug. The port is controllable only from the serial or Ethernet control ports and not the front panel controls of the unit.

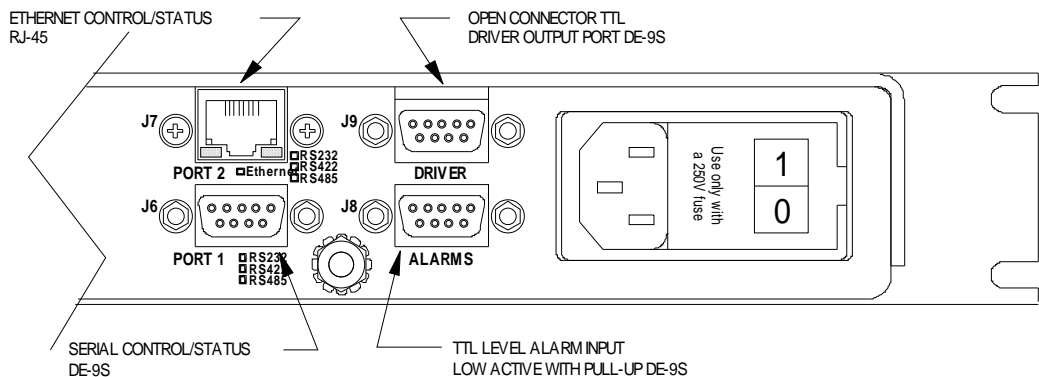

Being sized to 8-bits, the user can write a number from 0 (zero) to 255 to the port. Each output is an open collector driver output from an industry standard TTL technology 7406 device. Upon powering the unit, all lines are at the “open” state. When writing to the port, the associated line is driven low. A maximum of 40mA is supplied from each driver.

The level of these digital signals is referenced to chassis ground of the unit (ground). Writing a “zero” value to the port causes all eight (8) lines to be in the open collector state, while writing a value of 255 to the port will cause all lines to be driven low.

Pin	Function
1	1 (LSB)
6	2
2	4
7	8
3	16
8	32
4	64
9	128 (MSB)
5	VCC (+5V)

The port is controlled from either the remote control serial or remote control Ethernet ports located on the rear of the unit. The following syntax must be followed:

Onnn{CR}

The syntax calls for a capital "O" followed by a value "nnn" that represents the decimal value of a binary number that is to be written to the 8-bit port. After execution of the command, the command is echoed back to the port it originated from, or an error code is returned (if an error occurred).



NOTE: If the TTL driver port is used to drive relays, be sure to provide diode suppression across each coil for each driver external to the unit. An inductive spike will damage the driver outputs.

7.3.1. Driver Port Capacity

The J9 driver port has the capacity to control up to eight (8) devices or digital lines that are TTL compatible. The drivers are open collector type allowing the outputs to drive devices other than TTL logic. The drivers are from the TTL family of logic and are type 7406. This type of device can handle a maximum of +15V and can sink a maximum of 40mA at each output.

Below is an example diagram.

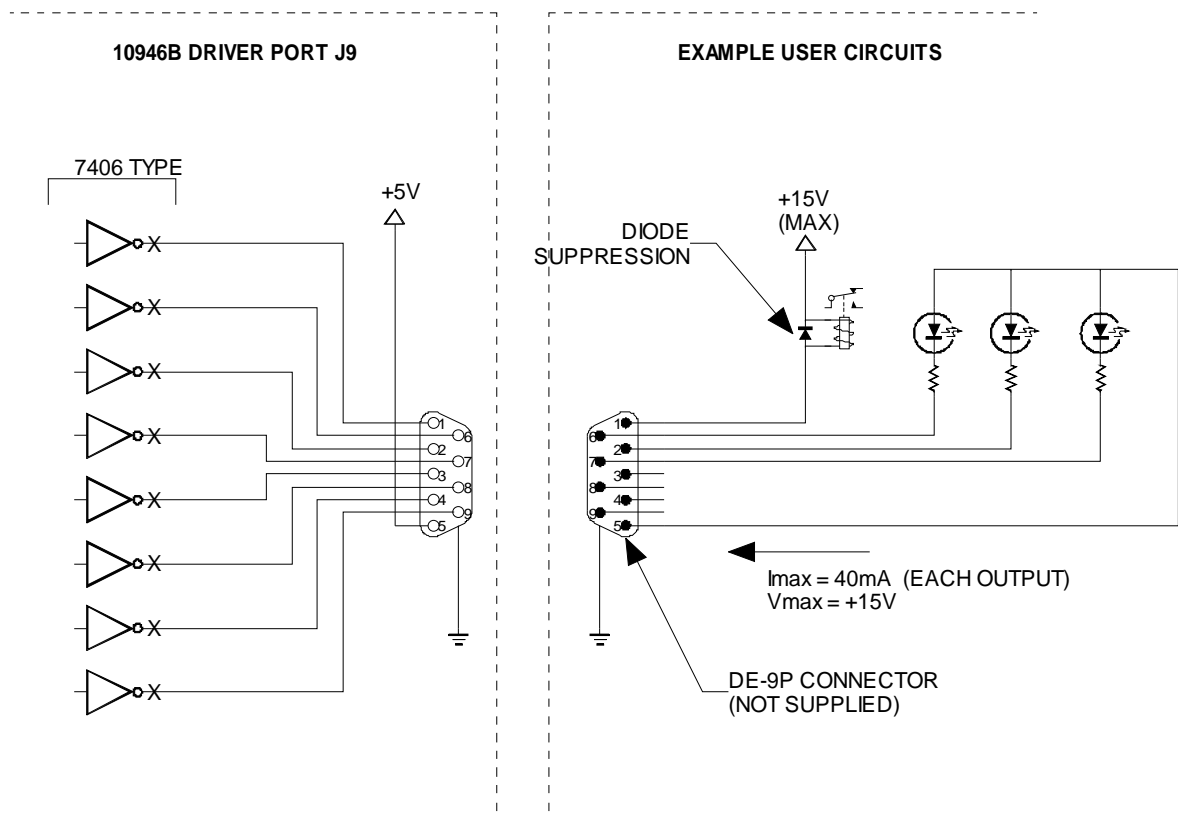

FIGURE 1.FOV

8. Spare Parts List

Following is a recommended listing of spare parts for the 10946B-SE10 system.

8.1. Factory Recommended Spares List

For situation critical installations, standard system engineering practice recommends sparing of certain critical items in order to ensure low/no down times. The factory recommended spares list for this unit is as follows:

Quantity	Model or P/N	Description
1	PS10946B-001	Plug-in Power Supply Assembly (AC version)
1	TBD	Plug-in Power Supply Assembly (DC version)



NOTE: Plug-In Power supply types are specific to the type of power used for the system (AC or DC). These power supply modules are unique to the power format of the system and **CANNOT** be interchanged. Be careful when ordering spare power supply units to specify the correct power type for your system.

9. System 10946B-SE10 Specifications

• Configuration	Four relay section A/B backup
• Frequency range	DC - 6GHz
• Insertion loss	<0.10dB @ 1GHz <0.15dB @ 2GHz <0.20dB @ 2 to 4 GHz <0.30dB @ 4 to 6GHz
• Isolation	>80dB @ 1 to 4GHz >70dB @ 4 to 6GHz
• VSWR	<1.10:1 @ 1GHz <1.15:1 @ 2GHz <1.20:1 @ 2 to 4GHz <1.30:1 @ 4 to 6GHz
• Impedance	50 ohms
• Signal connectors	SMA female
• Switching technology	High frequency relays
• Switching speed	15ms
• AC power	90-264VAC <10 Watts 47-440Hz
• Power cord	NEMA 15A (USA), 6 foot long (detachable)
Control Types	Serial Ethernet (10946B-SE10 only) Front panel illuminated keypad External "alarm" input
• Control connector	DE-9S type (serial, driver and alarm ports) RJ-45 type (Ethernet port)
• Operation temp range	0 to +60C
• Storage temp range	-20C to +85C
• Physical size	19.00" W x 9.50" D x 1.72" H
• Weight	<5lbs

10. Record of Changes

This section only applies to revised manuals. The table below indicates the revision level entered and a brief description of change(s) incorporated into the manual.

Revision	Description of Change	Date

EUROPEAN UNION DECLARATION OF CONFORMITY INFORMATION TECHNOLOGY EQUIPMENT



Coaxial Four Channel Backup System
Classified as Control and Measurement Equipment
Series – 10946B-SE10

Council Directive ---- 73/23/EEC Low Voltage Directive (LVD)
Council Directive ---- 89/336/EEC EMC Directive

The Product cited above (and its variations) complies with the following Safety, RF Emissions and Immunity Standard when installed and operated in accordance with the Users Instructions provided. The product, with its accompanying modules is declared to comply by virtue of Design, validated by Third Party Evaluation and Testing. EMC Testing and Evaluation were conducted by NATIONAL TECHNICAL SYSTEMS, an independent EMC Test Laboratory, located in Fullerton, CA 92631, USA. Product Safety Evaluations and Risk Assessments were conducted by ARROWHEAD STANDARD, INC., located in Dana Point, CA 92629, USA.

PRODUCT SAFETY/LOW VOLTAGE DIRECTIVE

EN61010 Safety Requirements for Electrical Equipment for Measurement, Control and Laboratory Use.

RF EMISSIONS AND IMMUNITY/EMC DIRECTIVE

EN55011: 1991	Emissions Limits for Industrial, Scientific And Medical (ISM) RF Equipment	Class B Conducted and Radiated
EN61000-4-2	Electrostatic Discharge Immunity	Level 2
EN61000-4-3	Radiated Emission Immunity	Level 2
EN61000-4-4	Electric Fast Transients Burst	Level 3

We the undersigned hereby declare that the equipment specified above conforms to the noted Directives and Standards in accordance with the LVD and EMC Directives. Refer to Technical Construction File USC 99201, provided upon request.

IMPORTER

(Signature)

(Typed Name)

(Title)

(Date)

Verified to be Compliant by: Chuck Helton, V.P. Regulatory Compliance
Arrowhead Standard, Inc., 33831A El Encanto, Dana Point, CA 92629